

Service Manual

For Overhaul and Inspection

Semi-Hermetic Single Screw Compressor Version III

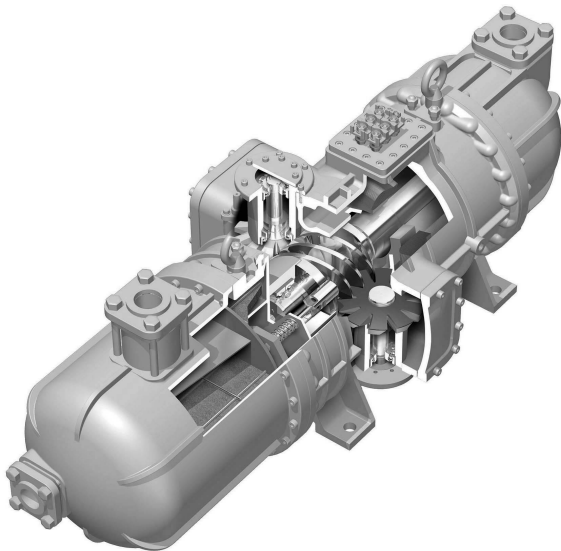

[Applied Models]

ZH(C)3LSF□	ZH3LMF□	ZH(C)3LTG
ZH(C)5MLF□	ZH5SLF□	ZH(C)3WLG
ZH(C), (A)5LLF□	ZH5LMF□	ZH(C), (A)5LMG
ZH(C), (A)7SLF□	ZHA7MLF□	ZH(C), (A)5WLG
ZH(C)7LLF□	ZHA7MSG□	ZH(C)7LSG
ZH(C), (A)9SLF□	□	ZH(C), (A)7WSG
ZH(C), (A)9LLF□	□	ZH(C), (A)9LSG
□	□	ZH(C), (A)9WSG

Semi-Hermetic Single Screw Compressor Version III

1. Scope of Application	2
2. Overhaul.....	3
3. Periodic Inspection.....	4
3.1 Periodic Inspection Items and Intervals.....	4
3.2 Periodic Inspection Instructions.....	5
4. Overhaul Instructions	10
4.1 Disassembly and Inspection.....	11
4.2 Replacing The Bearing.....	20
4.3 Final Assembly.....	24
5. Airtightness Test	29
6. Charging Oil	30
7. Caution in Test Operation	31
8. Required Tools.....	32

[Applicable Models]

ZH3LSF	ZH3LMF	ZHC3LSF		ZH3LTG	ZHC3LTG	
ZH5MLF	ZH5SLF	ZHC5MLF		ZH3WLG	ZHC3WLG	
ZH5LLF	ZH5LMF	ZHC5LLF	ZHA5LLF	ZH5LMG	ZHC5LMG	ZHA5LMG
ZH7SLF		ZHC7SLF	ZHA7SLF	ZH5WLG	ZHC5WLG	ZHA5WLG
ZH7LLF		ZHC7LLF	ZHA7MLF	ZH7LSG	ZHC7LSG	ZHA7MSG
ZH9SLF		ZHC9SLF	ZHA9SLF	ZH7WSG	ZHC7WSG	ZHA7WSG
ZH9LLF		ZHC9LLF	ZHA9LLF	ZH9LSG	ZHC9LSG	ZHA9LSG
				ZH9WSG	ZHC9WSG	ZHA9WSG

1. Scope of Application

This booklet applies to semi-hermetic single screw compressor for use in Model F type (ZH_F), G type (ZH_G). Replacement intervals specified in the booklet are empirically worked out based on the design service life expected of the compressors operated under the design conditions, and are intended to provide a general guide by which to formulate a maintenance plan.

2. Overhaul

Generally, maintenance and inspection of equipment are important in preventing their failure and damage to them. Equipment, even without defective structure or components, gradually age and wear over long years of operation. For example, screw compressors, despite their apparent good operating condition, may face such problems as decreasing insulation resistance of the motor, oil deterioration, and worn and fatigued bearings during long periods of operation. Most of such changes with time are invisible from the outside in many cases, and it is only after an accident that they are noticed. For this reason, in the case of equipment required to be highly reliable, it is most important to grasp their wear condition precisely and take necessary measures against accidents if they are to maintain proper operating conditions for expanding service life.

Overhaul interval: 40,000 hours or 7 years, whichever comes first.
--

3. Periodic Inspection

“Periodical Inspection” means to inspect, adjust and clean various parts of devices and equipment at the scheduled interval.

3.1 Periodic Inspection Items and Intervals

Table 3-1 shows periodic inspection items and intervals. Conduct inspections at the earliest indicated inspection intervals.

Table 3-1 Periodic inspection items and intervals

No.	Item	Inspection
1	Measurement of motor insulation resistance	1 year
2	Inspection of refrigeration oil	7,500 hr or 4 years
3	Inspection of gate rotor	20,000 hr or 4 years
4	Inspection of suction filter	20,000 hr or 4 years

3.2 Periodic Inspection Instructions

1. Insulation Resistance of The Motor

■ Insulation Resistance Testing

A megger is used to apply voltage directly to an insulated object, measure leakage current through the insulated object, and find the insulation resistance values. Its scale is voltage / leakage graduated with such insulation resistance values.

The following equation holds:

Insulation resistance = applied voltage / leakage current



Note:

1. A megger indicates an increasing resistance value with time, because absorption current flows through the insulated object at an early stage, lowering the resistance value correspondingly.
2. Prohibit anyone from measuring insulation resistance in a vacuum.
It must be measured at atmospheric pressure or after the filling of refrigerant. The reason is that in a vacuum, the insulation ability of gas lowers, and thus electric discharge is apt to occur.

(Measuring Procedure)

- (1) Turn off the main power and operating power.
- (2) Remove the terminal cover.
- (3) Before measurement, disconnect the cables connected to the compressor or control panel.
- (4) Disconnect the CTP protector lead wire.
- (5) Conduct measurement.

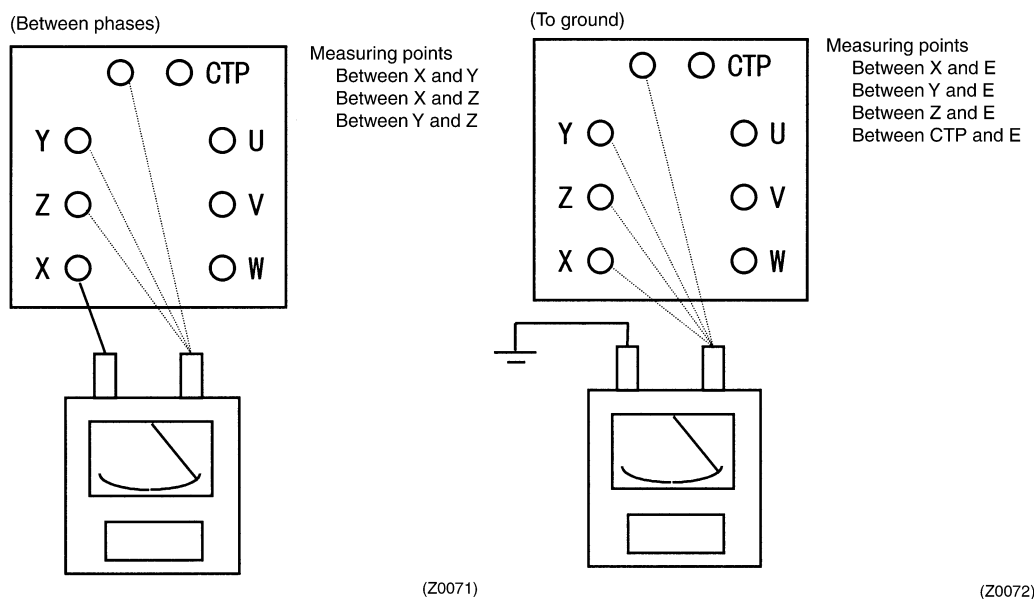

Fig. 3-1 Motor insulation resistance measuring method

(Measurement Standard)

Using a 500-V megger. The measured value shall be 3 MΩ or higher.

2. Changing Refrigerating Oil

Oil degrades after many hours of operation and due to aging. Replace oil regularly after 7,500 hours of operation or four years, whichever comes first.

(Changing Procedure)

- (1) Perform a pump down operation to reduce pressure inside the compressor.
- (2) Release the internal pressure of the compressor.
Loosen the flare nut at the service port (with check valve) of the compressor (see Fig. 3-2). Remove the partition lid, then tighten the flare nut to discharge refrigerant from the compressor. To loosen and tighten the flare nut, use two wrenches to turn the flare nut and keep the other nut stationary.

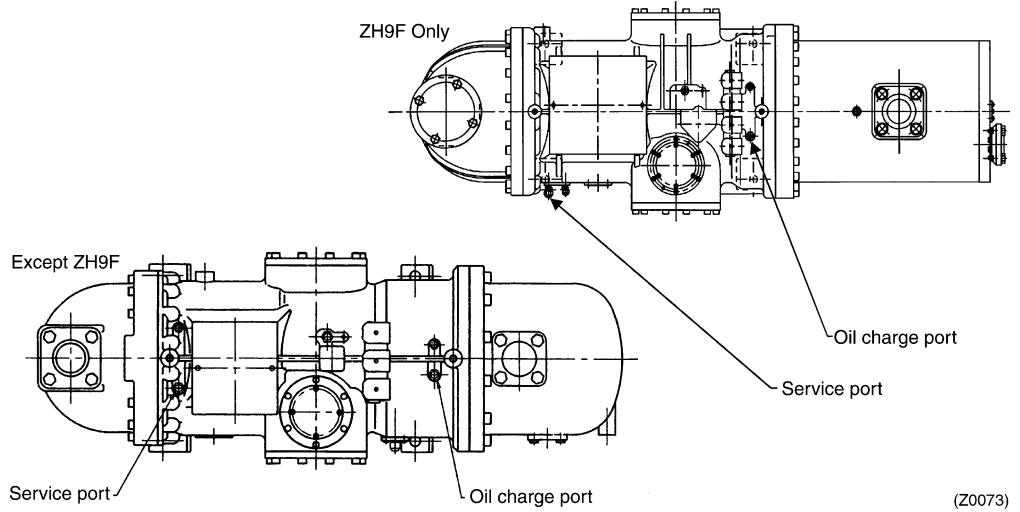

Fig. 3-2 Service port and oil charge port locations

- (3) After confirming that refrigerant is completely discharged, drain oil from the two drain ports located on the lower section of the casing.
The compressor rotates in the reverse direction when it stops operating. This causes oil to remain in the suction side. Therefore, be sure to drain oil from the two drain ports.

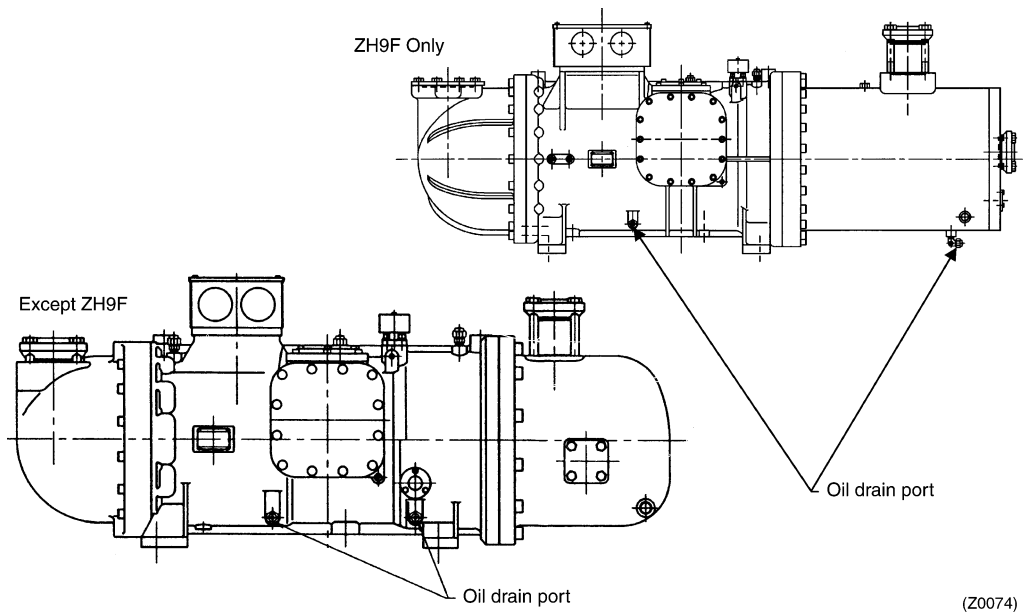

Fig. 3-3 Drain port locations

(4) Charging oil

Connect a vacuum pump to the suction service port (1/4" DCut) on the casing. While evacuating the compressor, add oil from the discharge service port (3/8" DCut).

- ① Use SUNISO 4GSD refrigeration oil (possible for use equal product) for refrigerant R22 and DAPHNE FVC68D refrigerant oil for refrigerant R407C and R134a.
- ② Add the same amount of new oil as drained because some remains in the refrigerant and on various parts inside. Drained oil contains refrigerant and appears to be more in volume than actual oil amount. Stir the oil to evaporate the dissolved refrigerant before measuring. Do not add more oil than necessary, since an excessive amount of oil reduces oil separation efficiency and causes system problems. (Oil surface should be visible on the level gauge during equipment operation.)
- ③ Take care not to let in air, or dust and other foreign particles remaining on the bottom of the oil container.
- ④ When charging oil from a previously opened container, conduct vacuuming of the compressor to remove moisture and air.

3. Inspecting The Gate Rotor

This inspection is done to check that no abnormal condition is present due to dust and other foreign particles inside or harsh operating conditions of liquid compression, etc..

- (1) Perform a pump down operation to reduce pressure inside the compressor.
- (2) Release the internal pressure of the compressor.
Loosen the flare nut of the service port (with check valve) of the compressor (see Fig. 3-2). Remove the partition lid, then tighten the flare nut to discharge refrigerant from the compressor.
- (3) Remove the side caps from both sides of the compressor. (Fig. 3-4)
Since a small amount of oil is still in the compressor, place drain pans under the side caps to receive oil before opening the side caps.

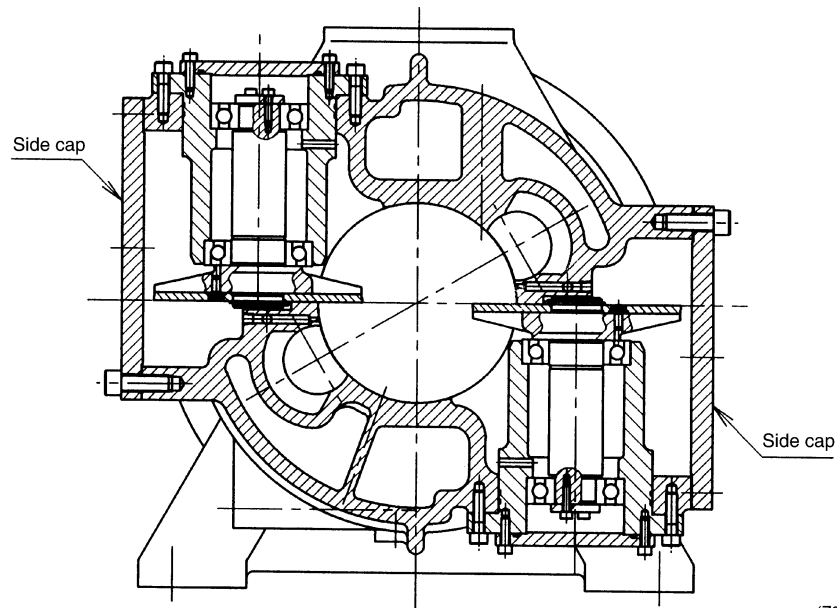

(Z0075)

Fig. 3-4 Side cap locations

(4) Inspection of the gate rotor

Visually check the gate rotor surface for scar, chipping, cracking, etc. Check all gate rotor teeth.

Table 3-1 Gate rotor inspection standards

Item	Standard	Remedy
Cracking	No cracking	Replace
Chipping	No chipping 3 mm or more long in long side	
Scar	No scar 1 mm or more deep	
Surface yellowing*	No yellowing	

- * When the yellowing is observed on the gate rotor blade, remove gate rotor and check the damage on outside of the screw rotor.
 If the damage on screw rotor is found, conduct one of the following counter measures.
- Repair (deburr, etc.) the damaged part of the screw rotor.
 - Replace the screw rotor.

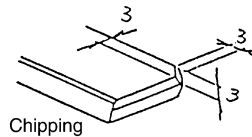

(Z0076)

Fig. 3-5 Inspection of gate rotor chipping

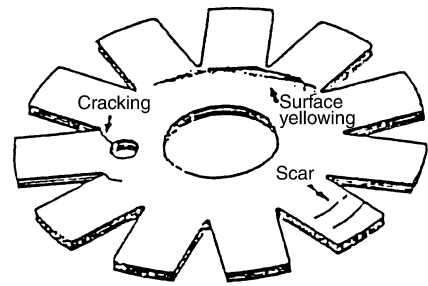

(Z0077)

Fig. 3-6 Inspection of gate rotor surface

(5) Measuring the slit clearance

The slit clearance is a gap between the gate rotor and casing, and it affects the compressor performance and reliability to a great extent. Therefore, the slit clearance must be set properly (60 to 90 μm).

While pressing the periphery of the gate rotor shaft with fingers, insert a thickness gauge into the slit clearance to measure the gaps on both suction and discharge sides. Be careful not to insert the thickness gauge too deep. If the thickness gauge is inserted too deep, it can be caught between the screw rotor and gate rotor and break.

(See Fig. 3-7 and 3-8.)

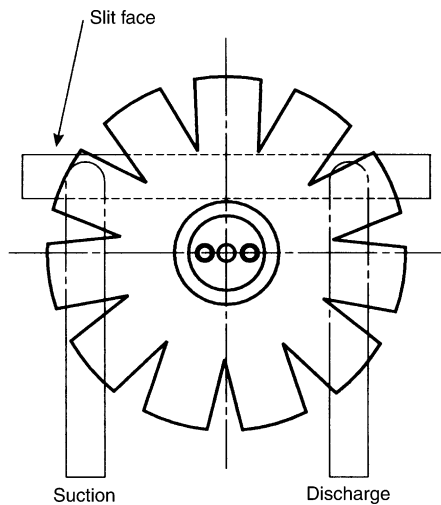

(Z0078)

Fig. 3-7 Slit clearance measuring location

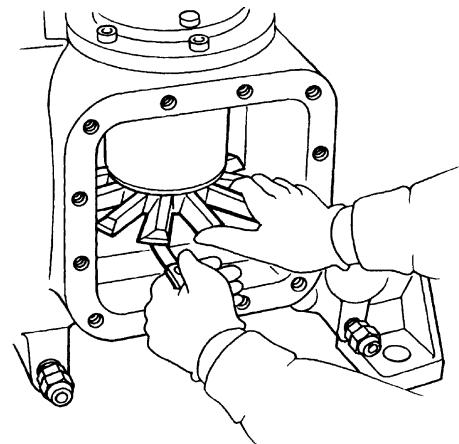

(Z0079)

Fig. 3-8 Measuring slit clearance on suction side

4. Cleaning The Suction Filter

- (1) Perform a pump down operation to reduce pressure inside the compressor.
- (2) Release the internal pressure of the compressor.
Loosen the flare nut of the service port (with check valve) of the compressor (see Fig. 3-2). Remove the partition lid, then tighten the flare nut to discharge refrigerant from the compressor. (Same as Section 3.2.2)
- (3) Disconnect the suction pipe, and remove the suction filter.
- (4) Remove dust and foreign particles from the inside of the filter by using compressed air and cleaning solution. Check the filter thoroughly for tears and damage. (Replace the filter if there is a tear.) Dry the filter thoroughly before installation to remove cleaning solution and moisture.

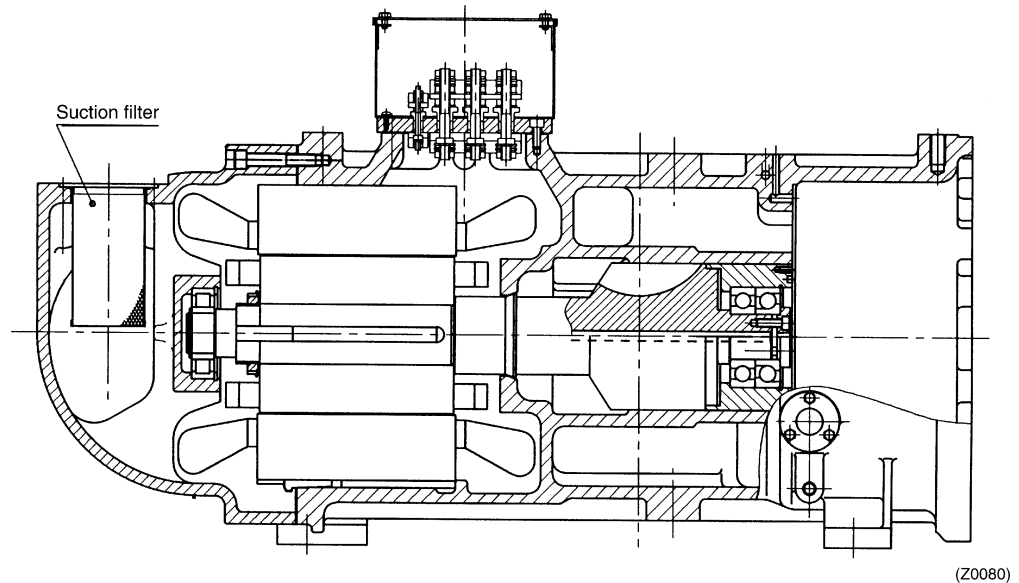

Fig. 3-9 Suction filter location (Cross sectional diagram of casing)

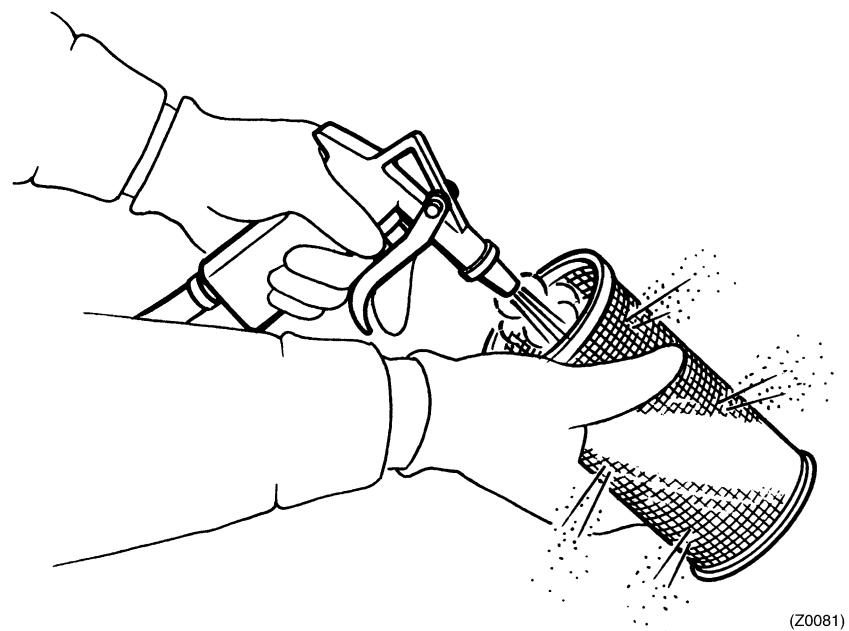

Fig. 3-10 Cleaning suction filter

4. Overhaul Instructions

The driving and friction parts in the compressor wear for prolonged over time. To prevent accidents caused by worn parts, it is necessary to inspect those parts regularly and overhaul the compressor as needed.

4.1 Disassembly and Inspection

1. Draining Oil

Drain oil by referring to Section 3.2.2 "Changing refrigerating oil."

2. Remove The Side Caps (One on Each Side) and The Discharge End Cover. (in case of ZH9F, oil collector)

- Receive remaining oil with a drain pan.
- Be sure to mount guide bolts when removing the discharge end cover.
- Be careful not to damage the oil filter with the discharge end cover.
- Locate the first demister between the discharge end cover and cylinder cover, and remove it. (Except ZH9F)

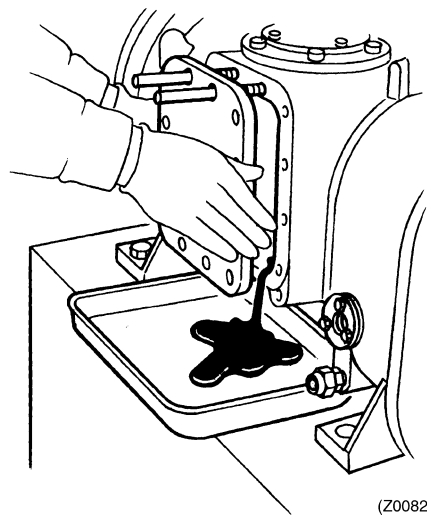

Fig. 4-1 Removing side cap

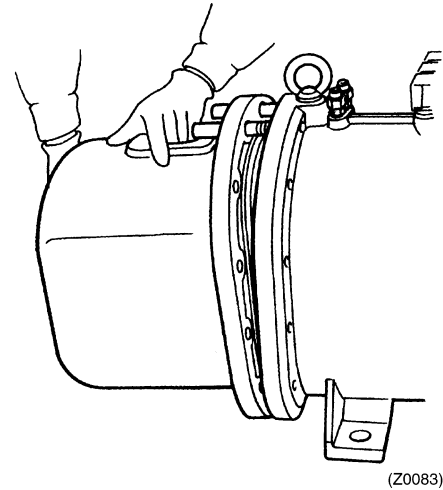

Fig. 4-2 Removing discharge end cover

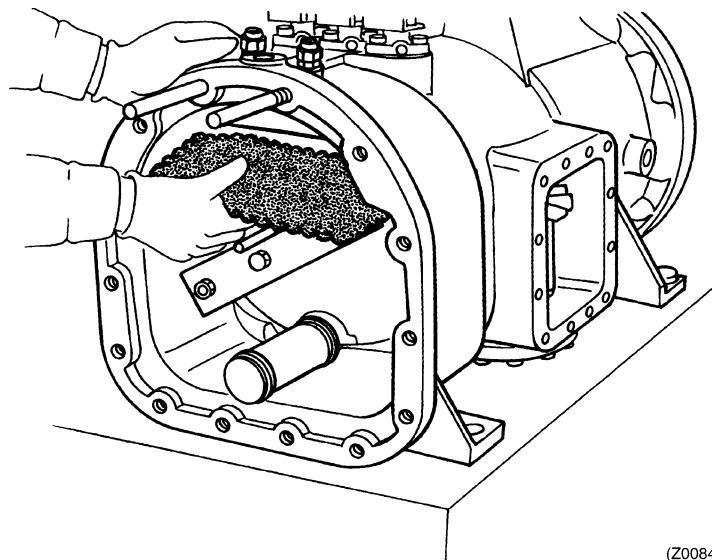

Fig. 4-3 Removing first demister

3. Inspection of The Gate Rotor and Surrounding Parts

(1) Checking the slit clearance

Measure the slit clearance by referring to Section 3.2.3) "Inspecting The Gate Rotor."

(2) Measuring the backlash

Measure the backlash of the gate rotor and screw rotor. If the measured value exceed the standard value, replace the gate rotor.

[Standard value] 0.15 mm or less for all teeth (ZH3, 5) and 0.20mm or less for all teeth (ZH7, 9)

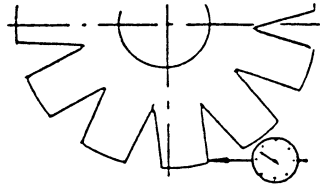

(Z0085)

Fig. 4-4 Measurement of gate rotor backlash

4. Disassembling The Gate Rotor and Surrounding Parts

(1) Positioning the screw rotor

Position the screw rotor so that the gate rotor can be removed without damage.

(2) Removing the gate rotor partition lid

In the ZH3F, the gate rotor partition lid is mounted together with the lower bearing holder.

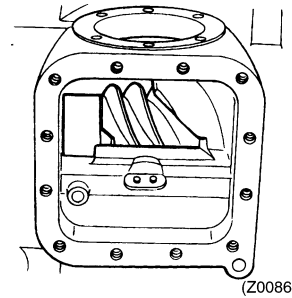

(Z0086)

Fig. 4-5 Screw rotor position

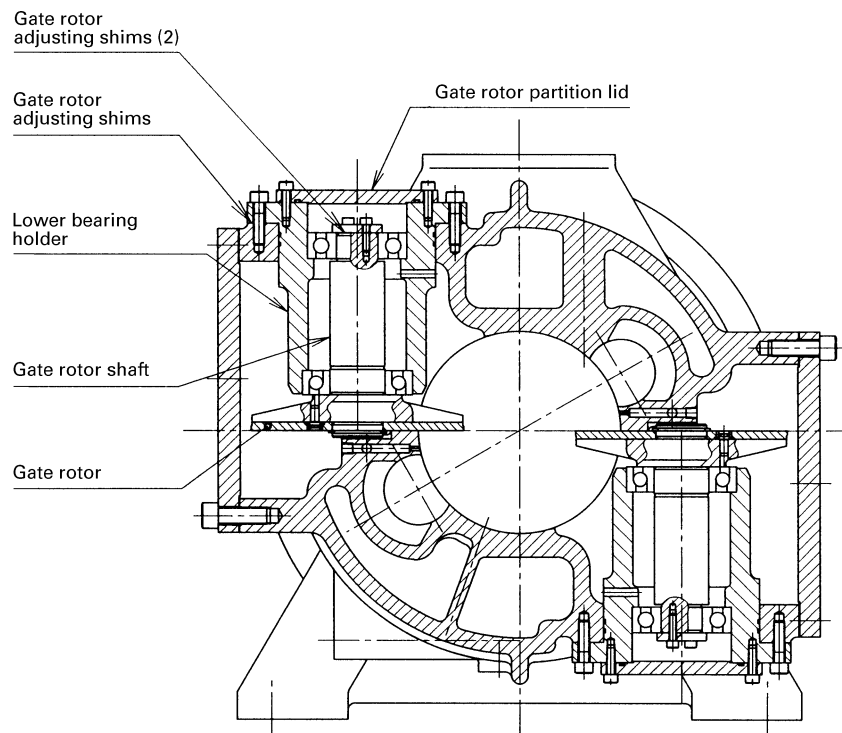

(Z0087)

Fig. 4-6 Cross sectional diagram of gate rotor

- (3) Removing the gate rotor bearing retainer plate
 While holding the gate rotor with hand, loosen the bolts. Be careful not to lose gate rotor adjusting shims (1) mounted between the gate rotor shaft and retainer plate. Be sure to use the original combination of gate rotor, lower bearing holder, gate rotor adjusting shims and gate rotor adjusting shims (2). (Do not exchange parts between the upper and lower sets).

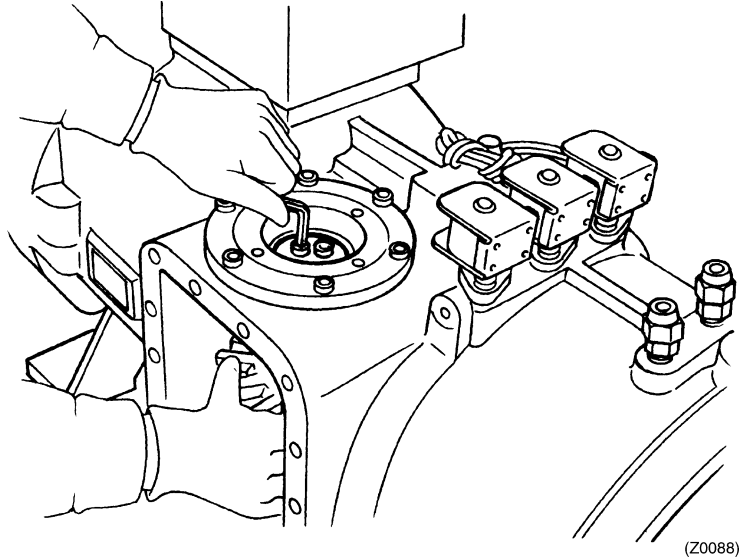

Fig. 4-7 Removing gate rotor bearing retainer plate

- (4) Removing the lower bearing holder (upward and downward units)
- ① In the guide bolt hole, thread the bolt that was used for the lower bearing holder mounting and lift the lower bearing holder from the casing.
 - ② Remove the shims inserted between the lower bearing holder and casing. (Do not lose the shims.)
 - ③ The lower bearing holder and casing are sealed by an O-ring. Therefore, it may be difficult to remove the lower bearing from the casing. To separate them, insert two standard screwdrivers at the flange section at locations opposite from each other, and slowly twist the screwdrivers, as shown in Fig. 4-8.

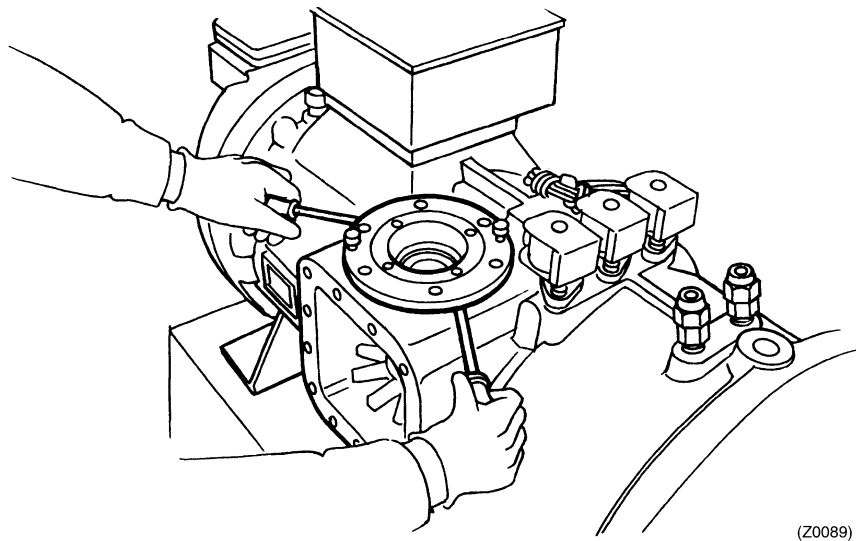

Fig. 4-8 Removing lower bearing holder

- ④ In the upward gate rotor, the lower bearing holder falls off when the O-ring is separated. Therefore, mount long bolts in the casing bolt holes and place a hand below the gate rotor to support it during removal operation.

- (5) Turn the gate rotor shaft to remove it from the screw rotor. Be careful not to damage the gate rotor.

5. Removing and Installation of Gate Rotor

- (1) Remove C type retaining ring.
- (2) Remove the gate rotor from the shaft.
- (3) Apply red check to the gate rotor, and check that the rotor is free of cracks.
If the rotor is found cracked, replace it with a new one.
- (4) Install the gate rotor on the shaft, and mount the C-type retaining ring.
The gate rotor has front and back sides. Position the gate rotor so that the manufacturing number is visible.

6. Removing The Suction End Cover

- (1) Remove all the mounting bolts.
- (2) Mount guide bolts in two bolt holes on the upper section.
(Be sure to mount guide bolts, since the suction end cover is heavy.)
- (3) In the guide bolt holes, thread the bolts that were removed previously, then remove the suction cover from the casing.
Locate positioning pins at two locations, and screw them.

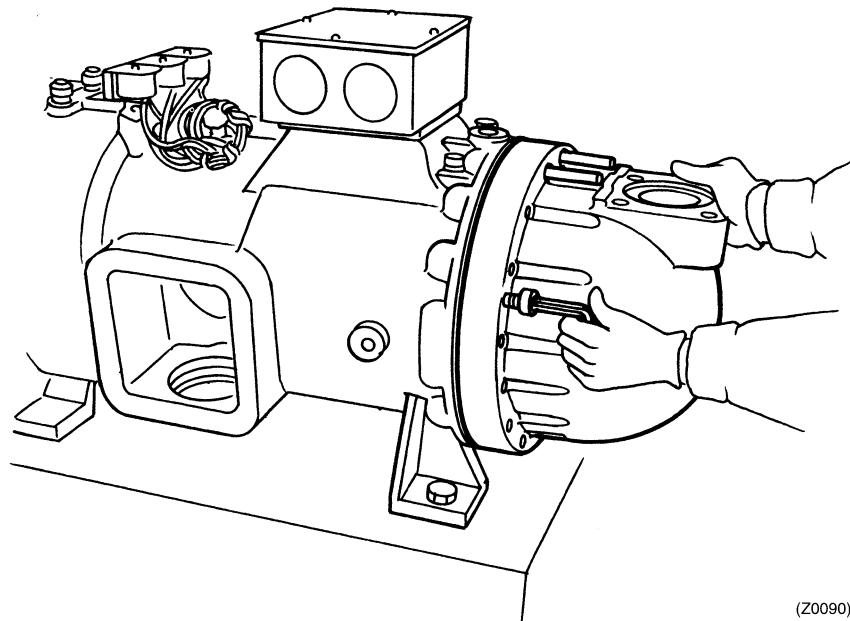
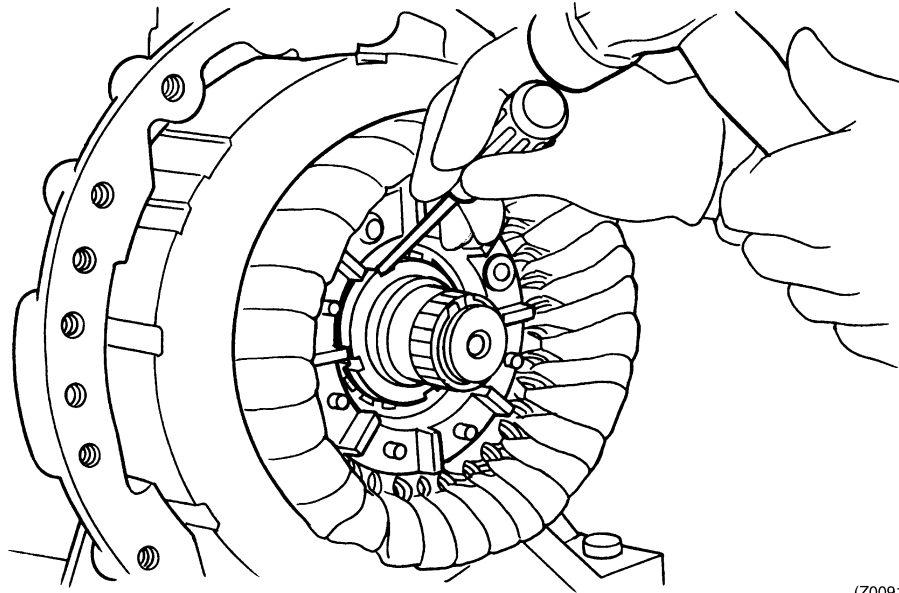

Fig. 4-9 Removing suction end cover

7. Removing The Motor Rotor

- (1) Remove the rotor locking plate using a standard screwdriver.
- (2) Loosen the lock nut. (Use the special tool or jig (1).)
- (3) As shown in Fig. 4-11 grip rotor fins with pliers, and remove the rotor. Securely support the rotor so as not to drop the rotor. At removal, be careful not to damage the stator coil end.
- (4) Remove the motor rotor key from the screw shaft.



(Z0091)

Fig. 4-10 Removing rotor locking plate

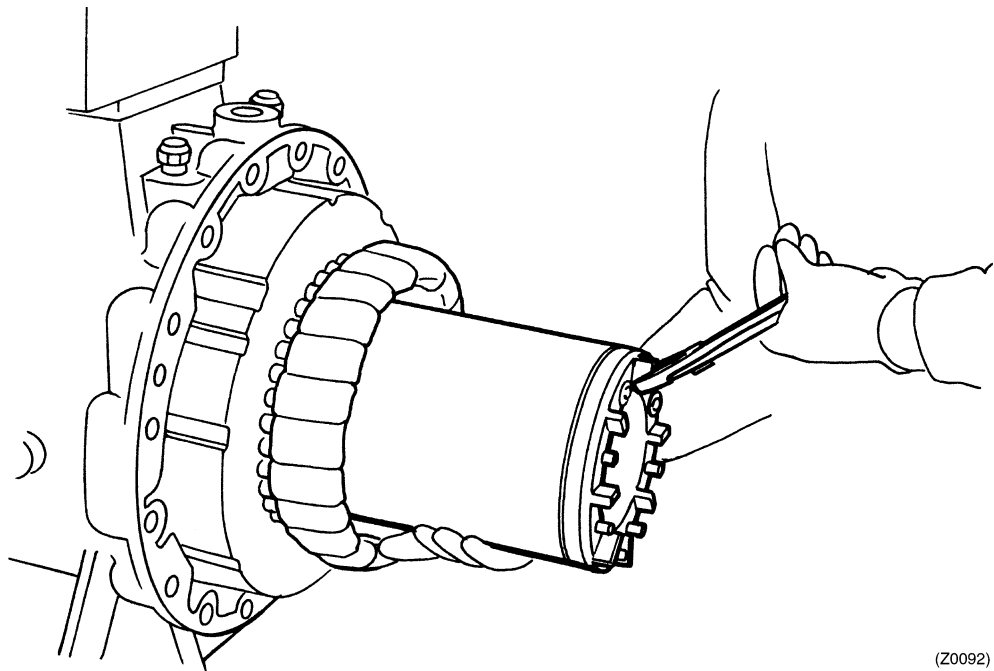

(Z0092)

Fig. 4-11 Removing motor rotor

8. Disassembly of The Controller

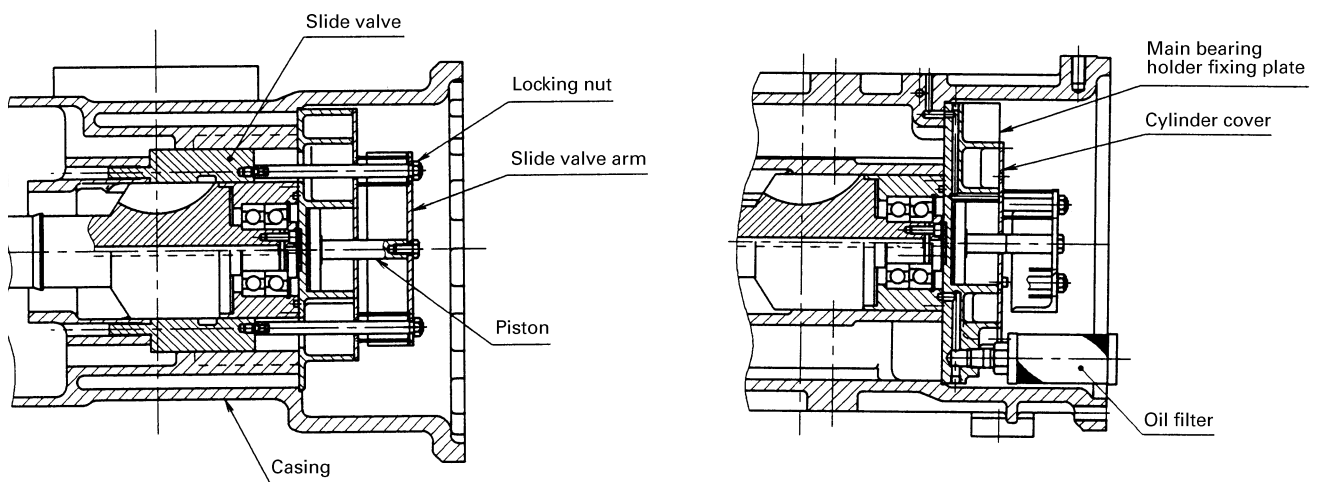

(Z0093)

Fig. 4-12 Cross sectional diagram of controller

- (1) Remove the slide valve arm.
 Loosen the two locking nuts of the slide valve shaft and the bolt at the center of the arm. A thread lock compound was used for the hexagon head bolt at the center. Use an impact wrench to loosen this bolt.

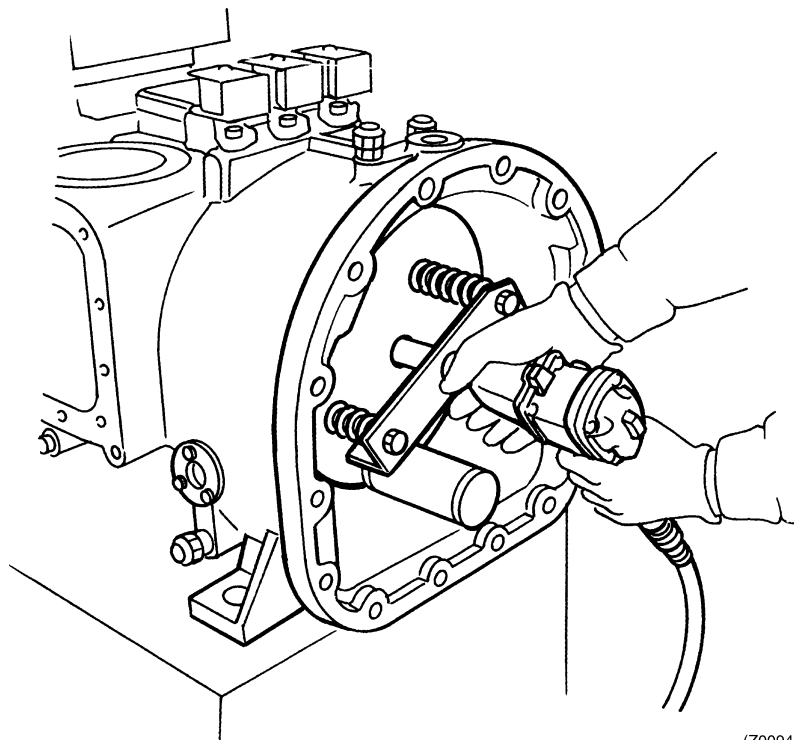

(Z0094)

Fig. 4-13 Removing slide valve arm

- (2) Remove the oil filter using the special tool, and clean. (ZH3F only)
 After cleaning, dry thoroughly.
 If the filter is damaged or torn, replace.

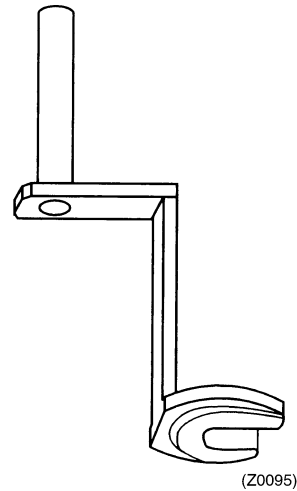

Fig. 4-14 Oil filter removing tool

- (3) Remove the mounting bolts, and remove the cylinder cover.
 (4) Pull out the piston.
 (5) Remove the mounting bolts, and remove the main bearing holder fixing plate.
 Use guide bolts when removing the fixing plate, since it is heavy.
 Do not lose screw adjusting shims (1) located inside.
 (6) Remove the oil filter from the fixing plate, and clean. (except for ZH3F)
 After cleaning, dry thoroughly.
 If the filter is damaged or torn, replace.
 (7) Remove the slide valve from the casing.

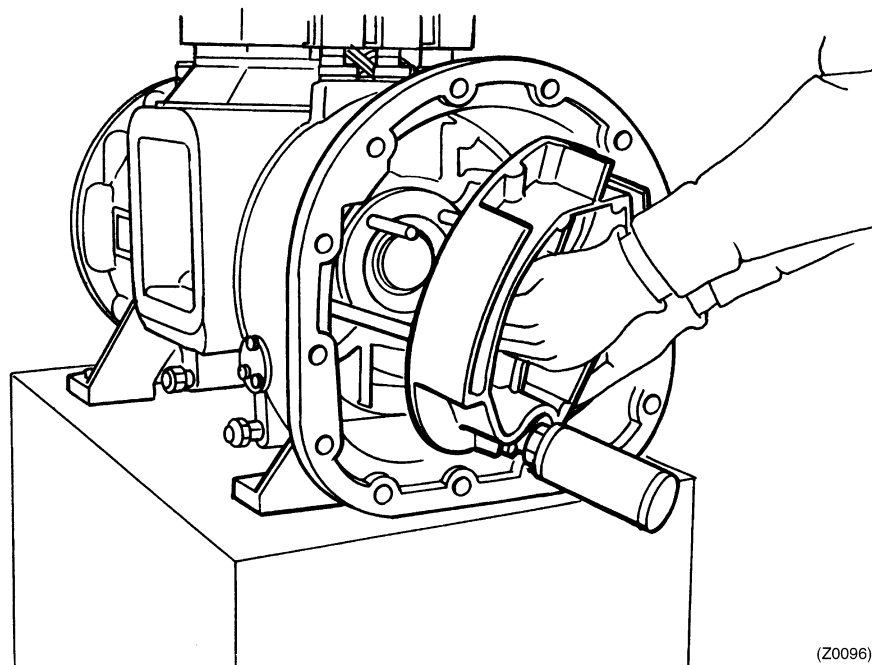
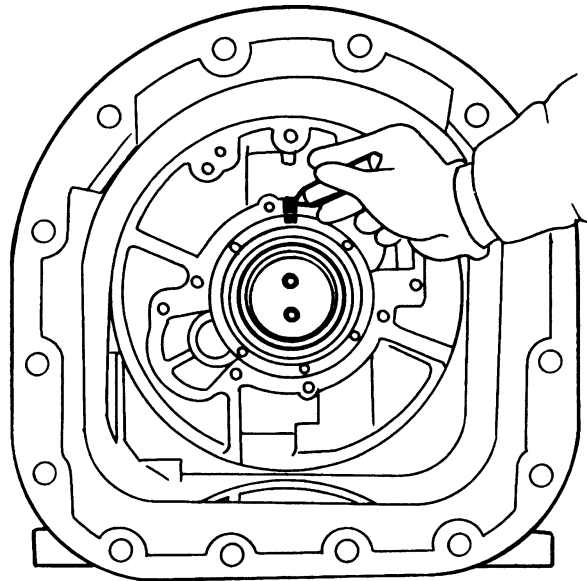

Fig. 4-15 Removing main bearing holder fixing plate

9. Removing and Disassembling The Screw Assembly Pulley

- (1) Place alignment marks on the casing and main bearing holder.



(Z0097)

Fig. 4-16 Placing alignment marks on casing and main bearing holder

- (2) Removing the screw shaft

Push the screw shaft from the suction side until the bearing holder completely extends from the discharge side. Then pull out the shaft from the discharge side. Insert one hand through the side cap hole and support the shaft to prevent the screw shaft from damaging the casing when the screw rotor section comes out of the casing. Use leather gloves during removal to prevent injuries by the screw and stator.

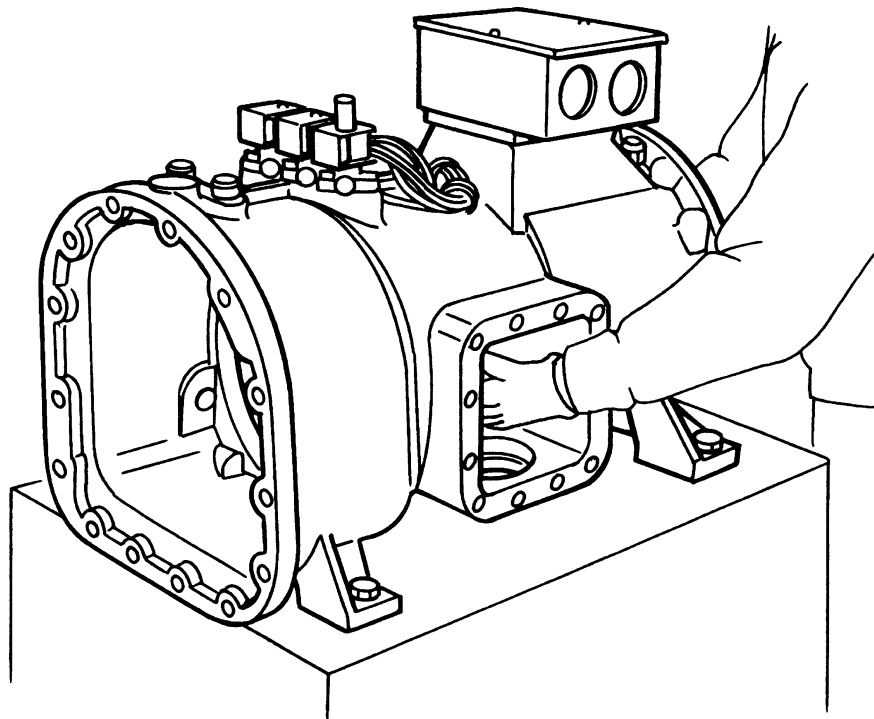

(Z0098)

Fig. 4-17 Removing screw shaft (1)

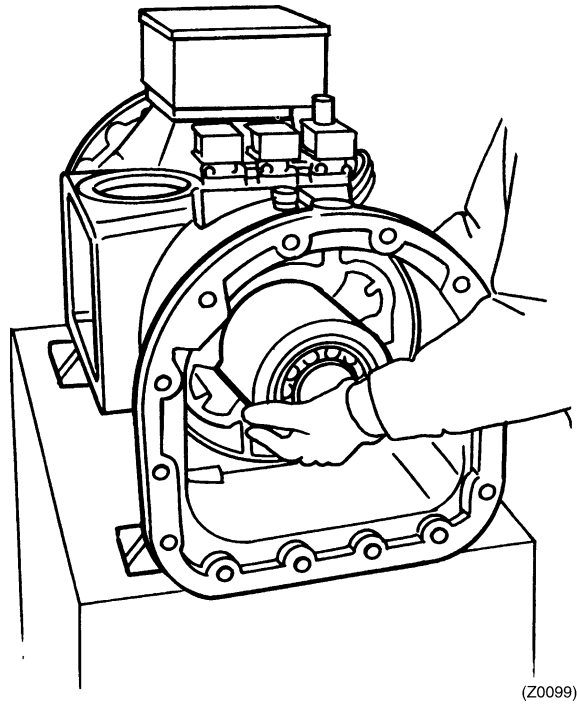

Fig. 4-18 Removing screw shaft (2)

(3) Disassembling the screw assembly

Remove the bolts, and remove the screw bearing retainer plate.

Remove the main bearing holder from the screw shaft. Do not lose screw rotor adjusting shims (2).

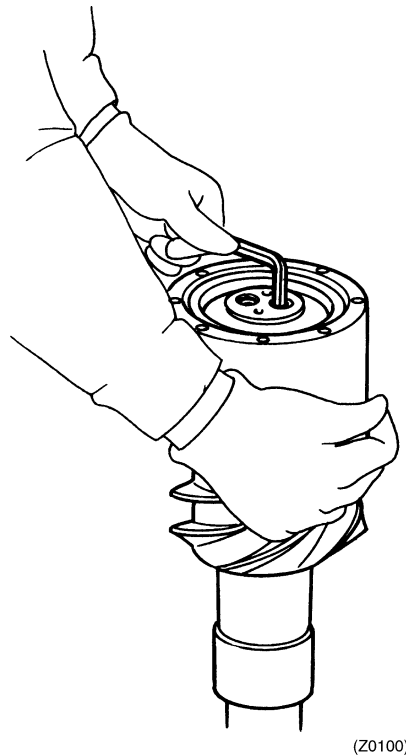

Fig. 4-19 Disassembling screw assembly

4.2 Replacing The Bearing

Unlike slide bearings, roller bearings have limited service life. They must be replaced regularly. To prevent accidents caused by worn roller bearings, replace all roller bearings during an overhaul.

4.2.1 Removing Bearings

1. Main Shaft Bearing

(1) Suction end cover (outer ring of cylindrical roller bearing)

- ① Remove the C-type retaining ring.
- ② Remove the outer ring of the bearing.

Use an ordinary bearing remover or special jig (2) to remove the outer ring.

(2) Screw shaft (inner ring of cylindrical roller bearing)

- ① Remove the C-type retaining ring.
- ② Remove the inner ring of the bearing by using a chisel.

Be careful not to scratch the screw shaft. If the screw shaft is accidentally scratched, remove burrs by grinding the irregular surface.

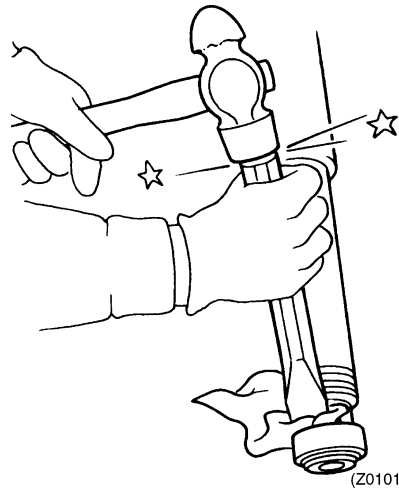

Fig. 4-20 Removing inner ring of screw shaft bearing

(3) Main bearing holder (angular-contact ball bearing, deep groove ball bearing)

- ① Removing the beveled C-type retainer ring

The beveled C-type retainer is securely installed in the groove to keep the bearing in place. For easy removal, first pry the end section of the C-type retainer ring toward inside using snap-ring pliers.

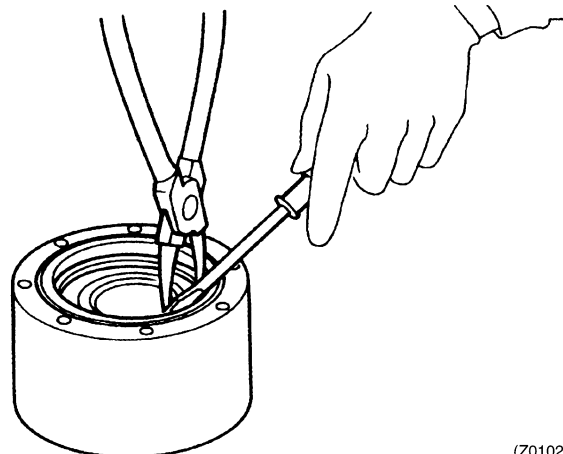

Fig. 4-21 Removing C-type retainer ring

② Removing the bearing

From the opposite side of the end with the C-type retainer ring, remove the outer ring of the bearing by placing a bronze rod and hammering it. Since the outer ring is not pressed in deeply, it can be removed easily.

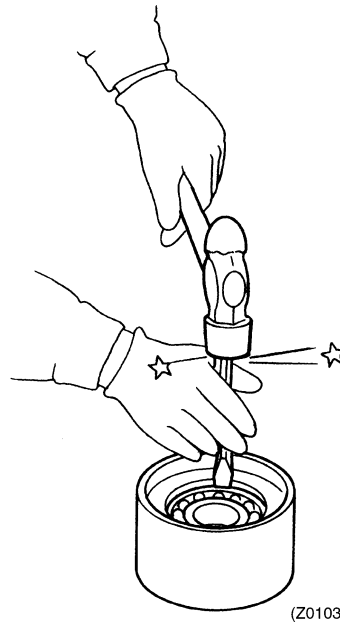

Fig. 4-22 Removing main bearing holder bearing

2. Gate Rotor Bearings (Angular-Contact Bearing, Deep Groove Ball Bearing)

Remove the angular-contact ball bearing and deep groove ball bearing from the lower bearing holder by using a bronze rod and hammer.

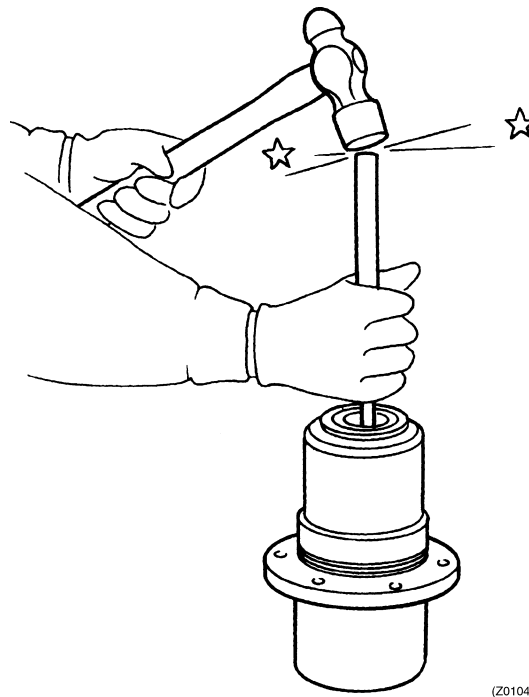

Fig. 4-23 Removing lower bearing holder bearing

4.2.2 Installation of Bearings

Before installing the bearings, clean the bearing holder and suction end cover.

1. Main Shaft Bearing

(1) Suction end cover (outer ring of cylindrical roller bearing)

Hammer the periphery of the outer ring of the cylindrical roller bearing to insert the bearing into the suction end cover bearing housing. Be careful not to damage the bearing when installing. Hammering the roller section can damage the holding section. After the bearing is installed securely in the housing, mount the C-type retainer ring to secure the bearing.

(2) Screw shaft (inner ring of cylindrical roller bearing)

Heat the inner ring of the bearing (120°C max.), and insert the tip of the screw shaft.

After the shaft is inserted, place a plate and hammer the shaft all the way. Then, mount the C-type retainer ring.

(3) Main bearing holder (angular-contact ball bearing, deep groove ball bearing)

Insert the bearings into the main bearing holder. Since fitting is tight, cool the bearings to a temperature of -50°C or lower using dry ice. After inserting the bearings, mount the beveled C-type retainer ring.

■ Be sure to install the bearings in the correct direction.

■ The beveled C-type retainer is tapered. After installation, hammer it into the groove.

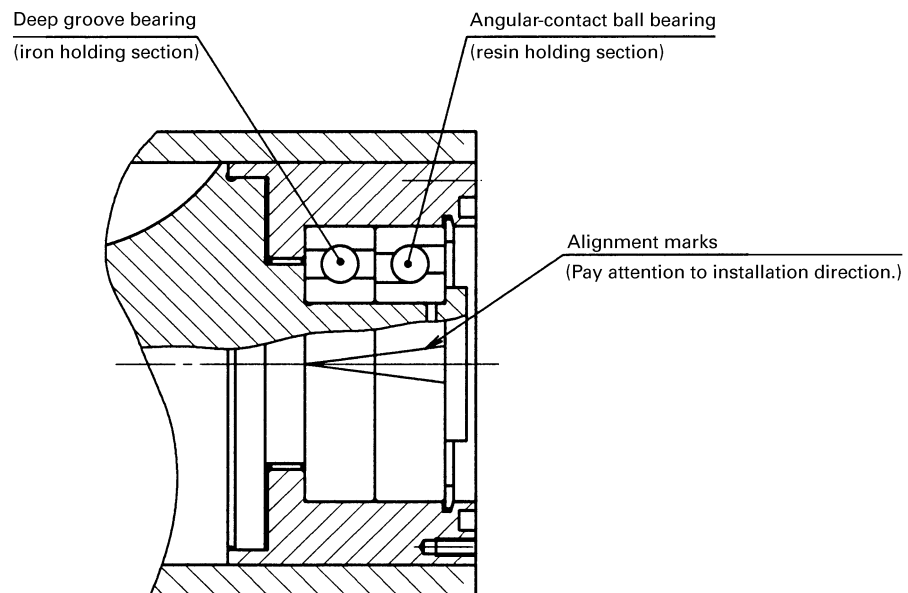

(Z0105)

Fig. 4-24 Direction of bearings

2. Installing and Adjusting The Gate Rotor Bearings

(1) Installing the bearings

Install the angular-contact ball bearing and deep groove ball bearing. The bearings must be press-fit, but they do not have to be pressed deeply. Hammer them evenly, and make sure that the bearings rest on the seats. Also, be sure to install the angular-contact ball bearing in the correct direction.

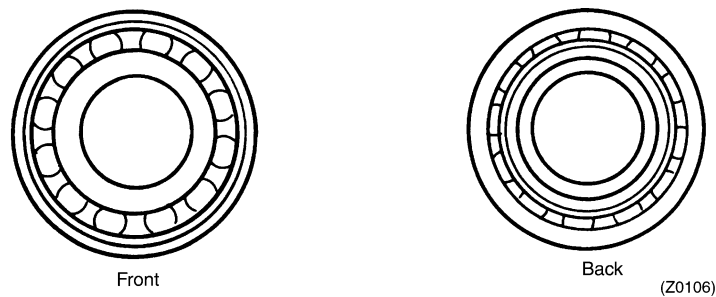

Fig. 4-25 Front and back sides of angular-contact ball bearing

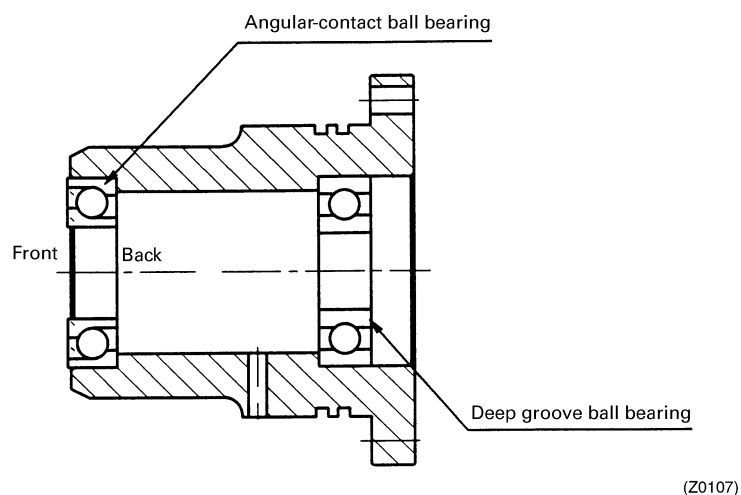

Fig. 4-26 Direction of bearings

(2) Adjusting the preload (temporary assembly)

Install the gate rotor shaft in the lower bearing holders mounted with the bearings, and check the preload of the bearings.

- ① Insert the gate rotor shaft into the bearings.
- ② Install gate rotor shims (2) and the gate rotor bearing retainer plate, and tighten the bolts to the specified torque.
- ③ Turn the gate rotor with full force by hand. The gate rotor must rotate smoothly and should not produce rolling sound.
 - a) When rolling sound is produced
Reduce the thickness of the gate rotor adjusting shims, and check again.
 - b) When gate rotor does not rotate smoothly
Increase the thickness of the gate rotor adjusting shims, and check again.
- ④ After adjustment, disassembly.
During disassembly, separate the shims, lower bearings and gate rotor shafts according to their installation locations (upward and downward units) so that they can be reinstalled in the original positions.

4.3 Final Assembly

Caution

- Clean the casing and all other parts, and dry them thoroughly.
- Use new packings and O-rings.

1. Assembling The Screw Shaft and Main Bearing Holder

Install screw adjusting shims (2) and the main bearing holder on the screw shaft, and install the screw bearing retainer plate. Tighten the two bearing retainer plate mounting bolts evenly.

Adjust clearance δ between 0.03 and 0.05 mm(except ZH9), 0.04~0.06mm(ZH9 only), as shown below. (Minimum clearance on periphery)

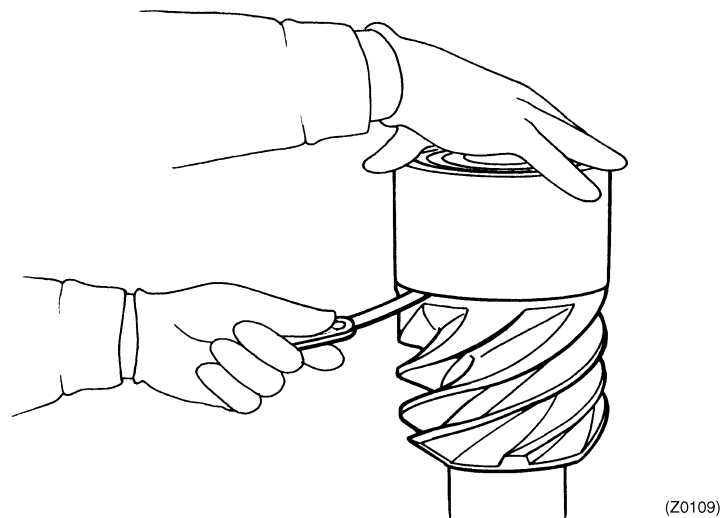
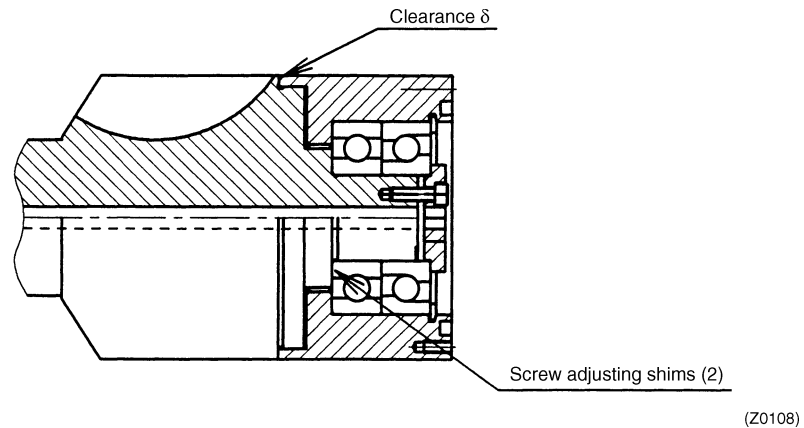
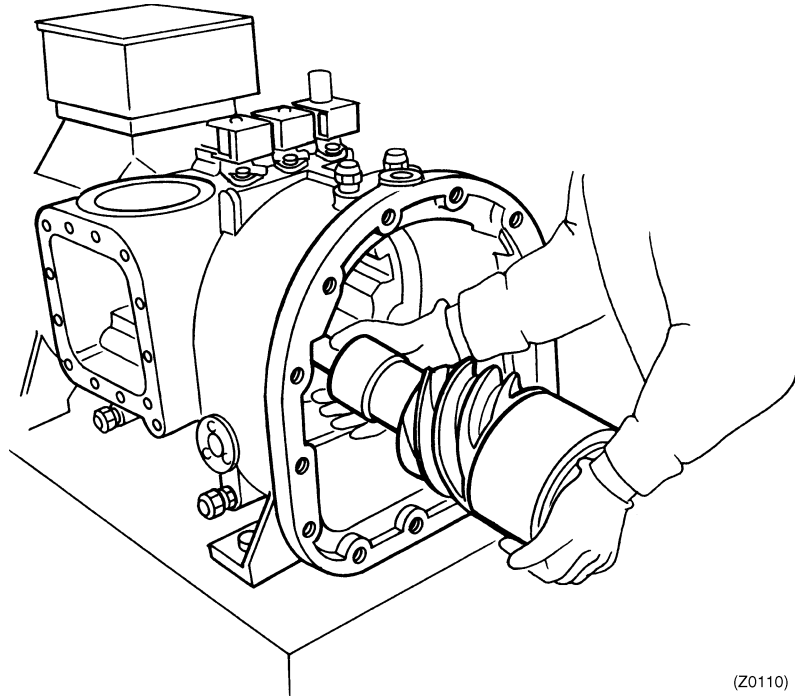

Fig. 4-27 Adjusting clearance between screw rotor and main bearing holder

2. Inserting The Screw Shaft

Insert the screw shaft into the casing until the shaft contacts the tapered section of the casing.

For this process, wear leather gloves to prevent hand injuries. (Do not use fabric work gloves.) The screw shaft is heavy, and the main bearing holder rotates, making it difficult to hold it. Be careful not to drop the screw shaft during installation.



(Z0110)

Fig. 4-28 Inserting screw shaft

3. Installing The Motor Rotor

- ① Insert the motor rotor key into the screw shaft from the suction side, and insert the motor rotor.

Insert the motor rotor in the direction shown below.

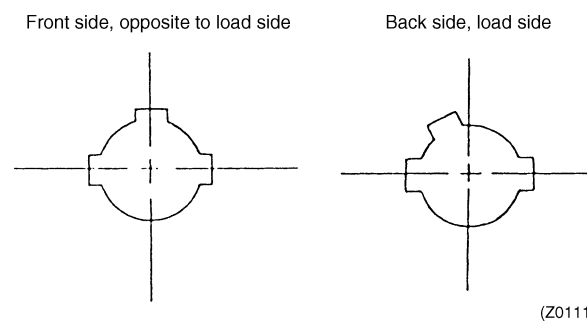

(Z0111)

Fig. 4-29 Motor rotor inserting direction

- ② Tighten the lock nut, and bend the tab on the lock washer to prevent the lock nut from loosening.

4. Installing The Suction End Cover

- (1) Extend the screw shaft from the motor side.
- (2) Install the suction end cover. In this step, use the two positioning pins to position the suction end cover. (Use guide bolts.)
- (3) Insert the screw shaft into the bearing of the suction end cover.
The holding section of the cylindrical roller bearing is made of plastic. It can break easily if applied with impact. Lift the screw shaft slightly higher than the side cap, and gently insert the screw shaft from the discharge side.

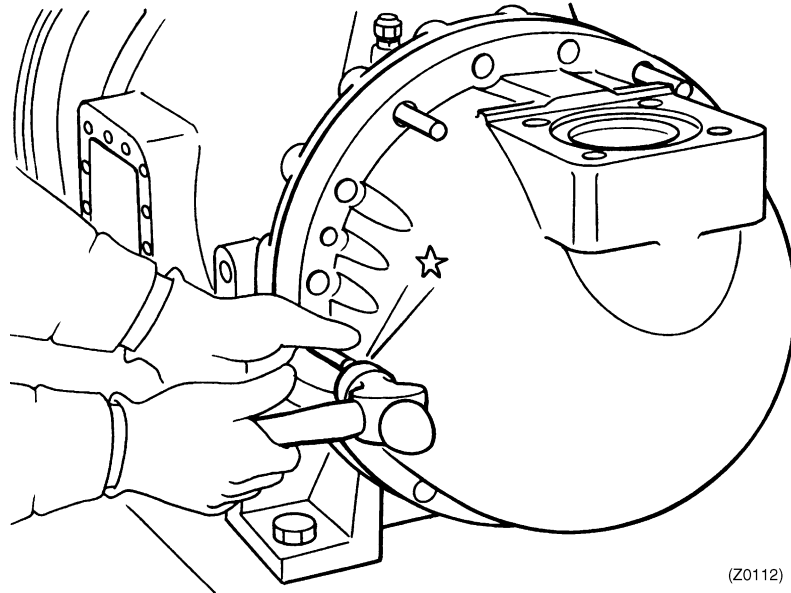

Fig. 4-30 Installing suction end cover

- (4) Rotate the screw rotor to make sure it moves smoothly.

5. Positioning The Screw Rotor

Mount jig (3) to the main bearing holder and casing. In this step, insert screw adjusting shims (1) between the jig and main bearing holder for the adjustment of the directional position of the screw rotor shaft.

6. Installing The Gate Rotor and Adjusting The Slit Clearance

- (1) Install the O-rings on the lower bearing holder. (ZH_F : two O-rings)
(ZH_G : three O-rings (two kinds))...Confirm the installing position on spare parts list.)
- (2) Set the screw rotor in the position indicated in Fig. 4-5, and engage the screw rotor with the gate rotor.
- (3) Apply oil on the O-rings of the lower bearing holder, and install the lower bearing holder in the casing.
 - ① After the lower bearing holder is inserted to the O-ring section, use the mounting bolt holes to press the lower bearing holder into the casing.
(Use bolts that are 5 to 10 mm longer than the mounting bolts. Using the mounting bolts may damage the threads since they are too short for this process.)
 - ② Before the casing and the flange of the lower bearing holder contact, insert shims, and tighten securely.
- (4) Install the gate rotor bearing retainer plate.
(To prevent the gate rotor from rotating, hold the gate rotor by hand while tightening.)
- (5) Measure the slit clearance (gap between the gate rotor and casing) with a clearance gauge. With the clearance gauge hooked on the gate rotor, insert jig (4) into the screw bearing retainer plate. Rotate the screw rotor, and insert the gauge in the slit.
 - Standard value: 0.06 to 0.09 mm
 - If the measured clearance deviates from the standard value, adjust the thickness of the gate rotor adjusting shims.
(To increase the clearance, add shims.)
- (6) Mount the O-ring on the bottom cover of the lower bearing holder, and install the bottom cover of the lower bearing holder.
- (7) Install the side cap.

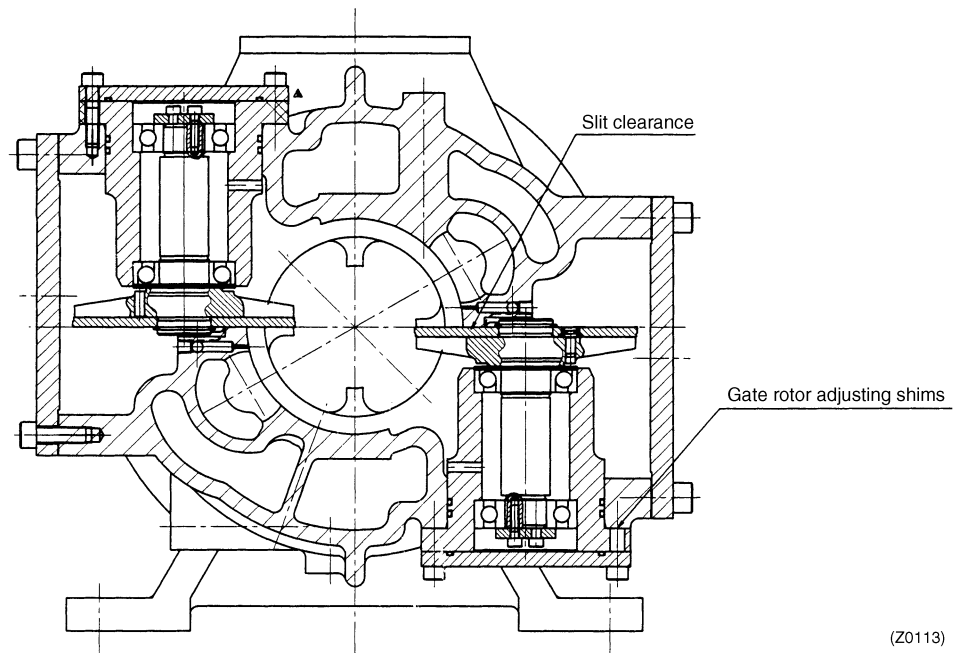

Fig. 4-31 Adjusting slit clearance

7. Installing The Main Bearing Holder Fixing Plate, Assembling The Controller, and Installing The Oil Filter

- (1) Insert the slide valve into the casing.
 - In the right hole, insert the slide valve with "2" stamped on the end surface.
 - Make sure the slide valve operates smoothly.
- (2) Mount the oil filter on the fixing plate. (except for ZH3F)
- (3) Remove jig (2), then install the fixing plate. During this step, insert guide bolts in the main bearing holder, and place the screw adjusting shims between the main bearing holder and fixing plate.
- (4) Insert the piston in the fixing plate

(In case of ZH_F)

- (5) Place the cylinder cover. Extend the piston until it contacts the cylinder cover, then tighten the four bolts around the cylinder. (After tightening bolts, make sure the piston moves smoothly.)

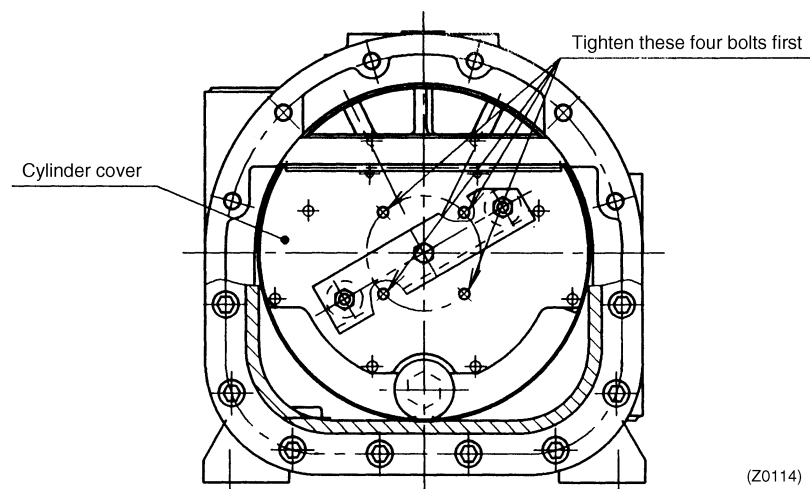

Fig. 4-32 Adjusting piston and installing cylinder cover

- (6) Tighten the other mounting bolts of the cylinder cover.

(In case of ZH_G)

- (5), (6) place the cylinder cover. Extend the piston until it contacts the cylinder cover, then tighten the bolts. (After tightening the bolts, make sure the piston moves smoothly.)

- (7) Install the oil filter using jig (5). (for ZH3F only)
- (8) Pull the slide valve forward, then hook the slide valve spring on the slide valve shaft. (upward and downward units)
- (9) Install the slide valve arm with the locking nut (slide valve) and bolt (piston). Use a thread lock compound (Loctite etc.) on the bolt, and use a new locking nut.

8. Installing The Discharge End Cover (In case of ZH9F, Oil collector)

Insert the first demister (except ZH9F) in the cylinder cover, and install the discharge end cover.

Since the discharge end cover is heavy, be sure to use guide bolts.

5. Airtightness Test

Using dry air mixed with refrigerant, pressurize to \bar{A} . Then, use a gas detector (or soap water) to check for leaks. Apply soap water on the side caps and other cover mounting sections to make sure no air bubbles are formed. If air bubbles are formed, release the pressure, then re-tighten the bolts. If the leak does not stop, check the packing seating surfaces and replace the packing.

refrigerant type	\bar{A}
R22	2.8MPa(28bar)
R134a	2.0MPa(20bar)
R407c	2.98MPa(29.8bar)

6. Charging Oil

Part of oil may remain in the refrigerating system. Therefore, charge the same amount of oil removed from the compressor during disassembly. When a new gate rotor is installed, pour about a half of the total oil capacity to the suction side to prevent excessive heating during initial operation.

7. Caution in Test Operation

- 1) Check to make sure all bolts are tightened.
- 2) Check the wiring for proper connection.
- 3) Conduct inching.
 - ① Check the rotating direction using high and low pressure gauges.
(If the rotating direction is correct, the low pressure gauge indicates decreasing and the high pressure gauge shows rising pressure.)
 - ② Check that no abnormal noise is generated.

8. Required Tools

1. General Tools and Measuring Instruments

Table 8-1 List of general tools and measuring instruments

	Name	Specification (size)	Application	
Tools	1	Hex-key wrenches	M5, M6, M8, M10, M12, M16	
	2	Torque wrench		Refer table 8-2
	3	C-type retainer ring removing tools	For holes (large, small) and shafts	Gate rotor and bearing holders
	4	Guide bolts	M6, M8, M10, M12, M16	Fixing plate and cover installation
	5	Other general tools	Adjustable end wrench, spanners, pliers, screwdrivers, hammer, plastic hammer, T-shape wrenches, chisel	
Measuring instruments	6	Megger taster	500-V megger	
	7	Depth gauge	Dial type (minimum scale division: 0.01 mm)	Screw shims (1)
	8	Thickness gauges	0.03 to 0.10 mm	Clearance between main bearing holder and screw and slit clearance
	9	Dial gauge	Minimum scale division: 0.01 mm, stroke: 10 mm	For measuring Backlash

Table 8-2. Tightening torque values for bolts (N - m)

Nominal screw size	5T	Class 12.9
M5	3.0	11.6
M6	5.2	14.0
M8	12.3	34.0
M10	25.2	68.0
M12	42.7	118
M16	103	293
M20	202	570
M24	348	—



Notes:

1. Indicate metric coarse threads and standard bolts (5T, 12.9).
2. Tolerances on tightening torque are $\pm 15\%$.
3. When tightening hexagon socket head cap screws in the compressor, apply specifications for class 12.9.

2. Special Tools

For an overhaul, be sure to prepare jigs listed in Table 8-3.

Table 8-3. List of special tools

Name used in manual	Tool name	Application	Applicable model
Jig(1)	Jig(1) Lock nut tightening jig	Motor rotor mounting	ZH3~9F, G
Jig(2)	Jig(2)-1	Bearing removing jig	ZH3, 5F
	Jig(2)-2		ZH3~9F, G
Jig(3)	Jig(3) Temporary bearing holder mounting plate	Centering of screw	ZH3~9F, G
Jig(4)	Jig(4)-1	Handle	ZH3, 5F
	Jig(4)-2		ZH3~9F, G
Jig(5)	Jig(5) Oil filter removing jig	Required only for ZH3F	ZH3F

Jig (1) [Lock Nut Tightening Jig]

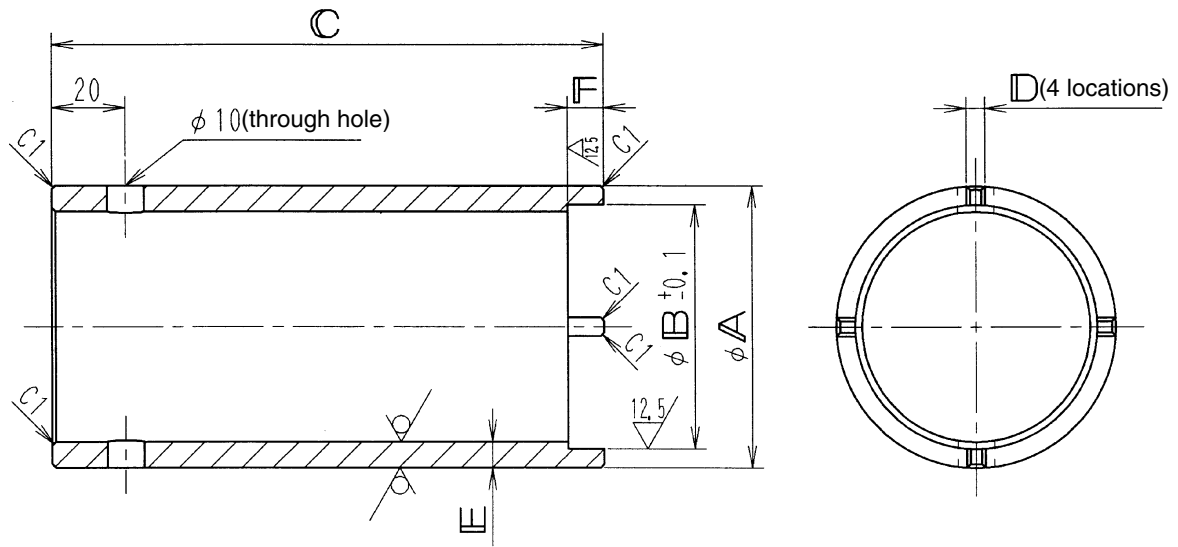

Applicable model	A	B	C	D	E	F	Material
ZH3_	76.3	66	150	5	7.0	10	STPG370E 65A, sch80
ZH5F, ZH7F	89.1	75	200	6	7.6	10	STPG370E 80A, sch80
ZH9F	101.6	92	250	7	8.1	12	STPG370E 90A, sch80
ZH5G	76.3	70	150	6	7.0	10	STPG370E 65A, sch80
ZH7G, ZH9G	101.6	86	200	7	8.1	11	STPG370E 90A, sch80

(Z0115)

Jig (2)-1 [Bearing Removing Jig Set]

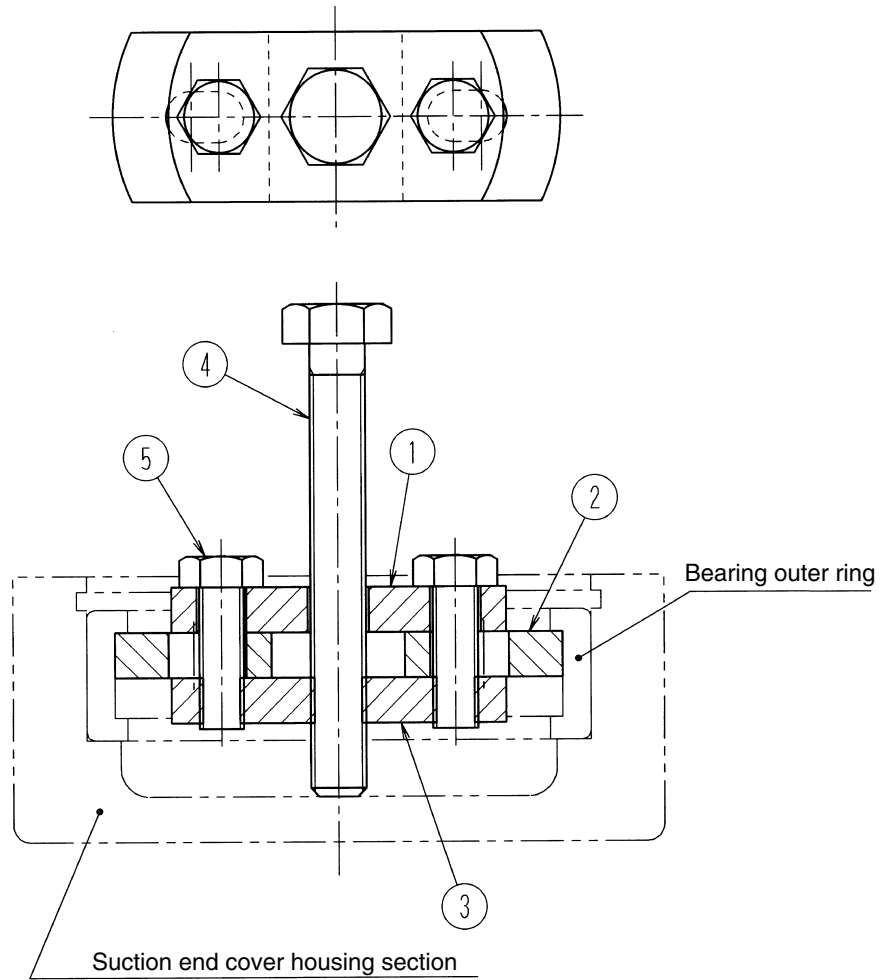

(Z0116)

Parts No.	Name	Quantity	Material	Remarks
①	Guide plate	1	SS400 or SM400A	See next page.
②	Batten(1)	2	SS400 or SM400A	See next page.
③	Batten(2)	1	SS400 or SM400A	See next page.
④	Removing bolt	1	S45C	JIS B1180 fully threaded hexagon head bolt A M10x70-10.9, chamfered end
⑤	Hexagon bolt	2	S45C	JIS B1180 hexagon head bolt with nominal diameter body A M8x25-5.6

Jig (2)-1 [Bearing Removing Jig Parts]

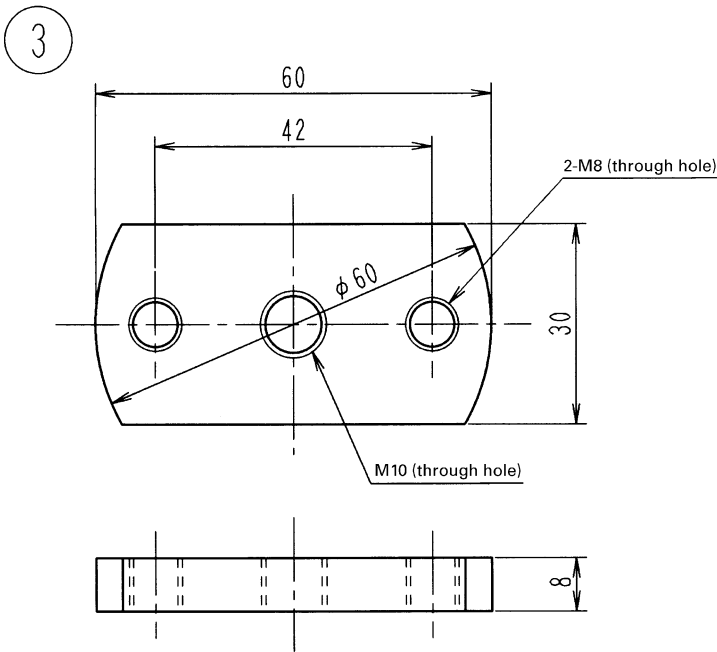
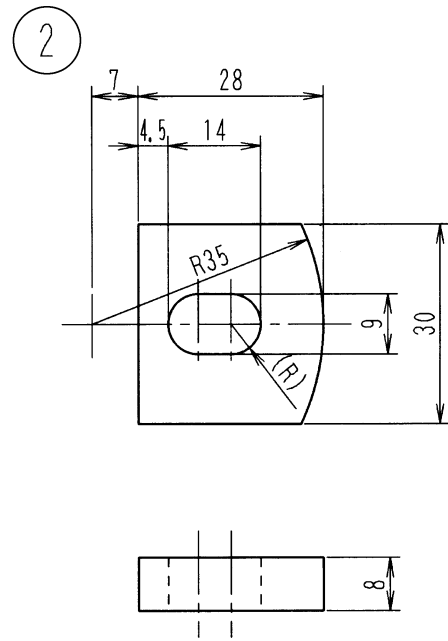
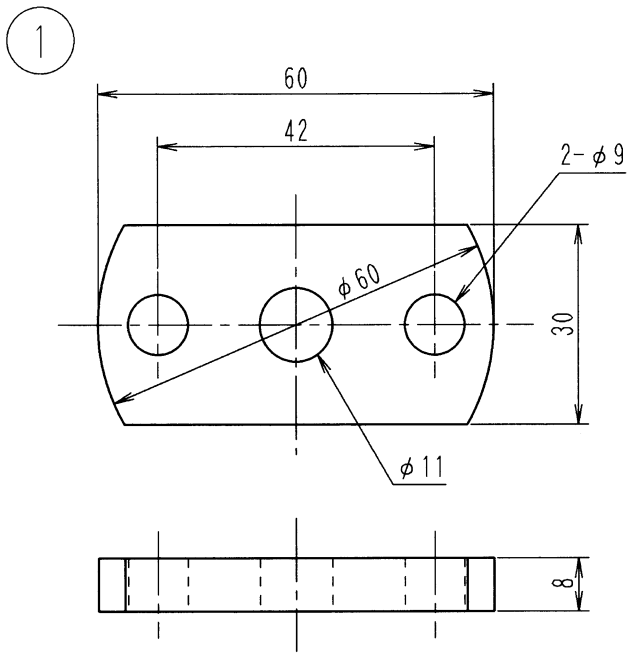

(Z0117)

Jig (2)-2 [Bearing Removing Jig Set]

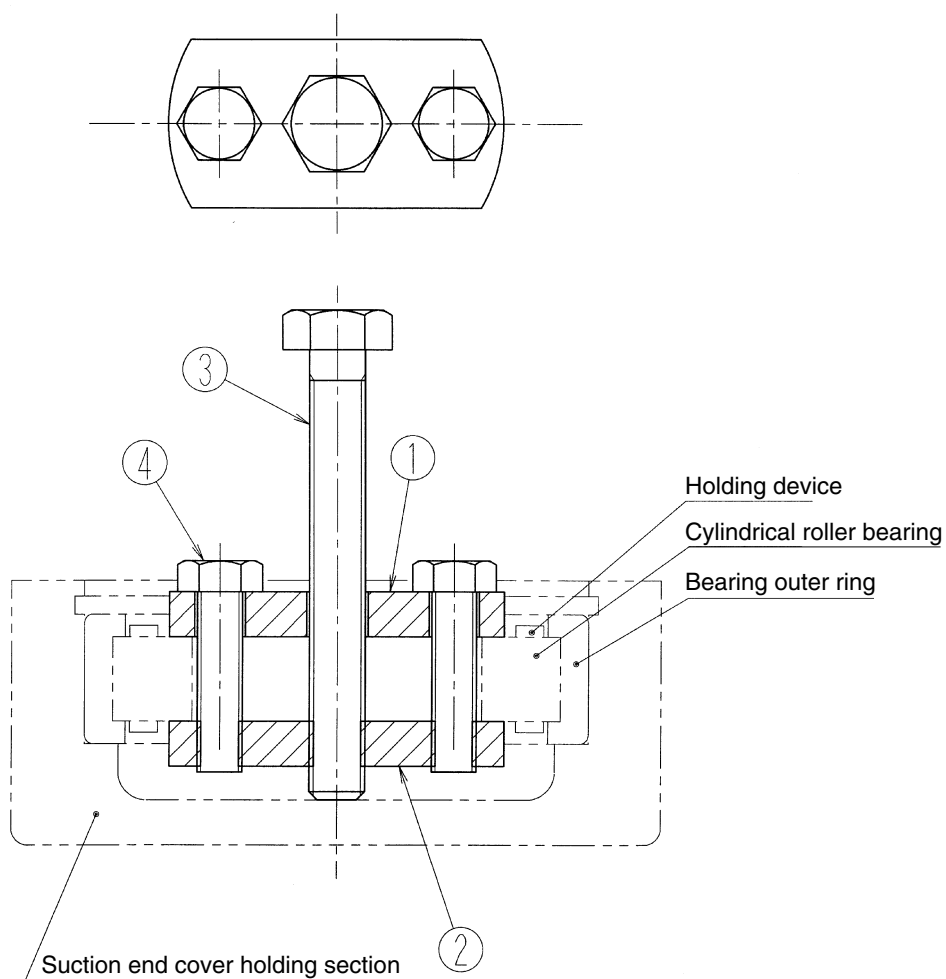

(Z0118)

Parts No.	Name	Quantity	Material	Remarks
①	Guide plate	1	SS400 or SM400A	See next page.
②	Batten	1	SS400 or SM400A	See next page.
③	Removing bolt	1	S45C	See next page.
④	Hexagon bolt	2	S45C	JIS B1180 hexagon head bolt with nominal diameter body A M6x30-5.6

Jig (2)-2 [Bearing Removing Jig Parts]

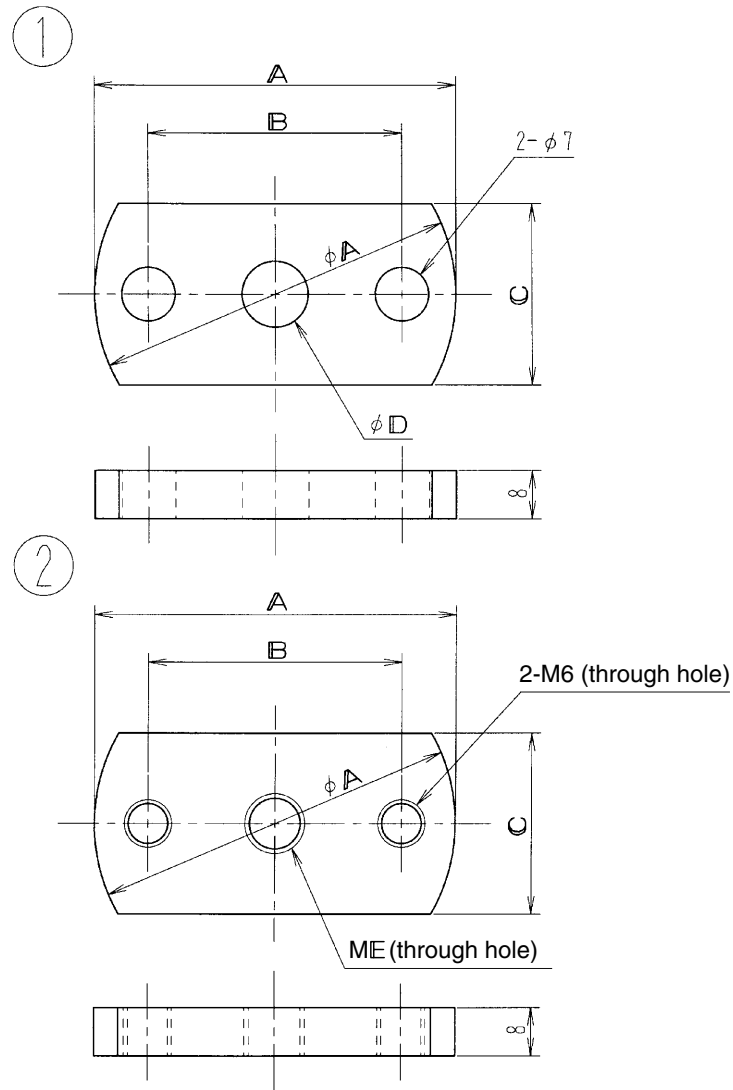

Applicable model	A	B	C	D	E	Removing bolt
ZH3_	54	30	25	9	8	JIS B 1180 fully threaded hexagon head bolt A M8x70-10.9 chamfered end
ZH5F, ZH7_	62	40	35	13	12	JIS B 1180 fully threaded hexagon head bolt A M12x70-10.9 chamfered end
ZH5G	46	30	25	9	8	JIS B 1180 fully threaded hexagon head bolt A M8x70-10.9 chamfered end
ZH9_	67	50	35	13	12	JIS B 1180 fully threaded hexagon head bolt A M12x70-10.9 chamfered end

(Z0119)

Jig (3) Temporary Bearing Holder Mounting Plate [jig]
[For ZH3_] Material: SS400

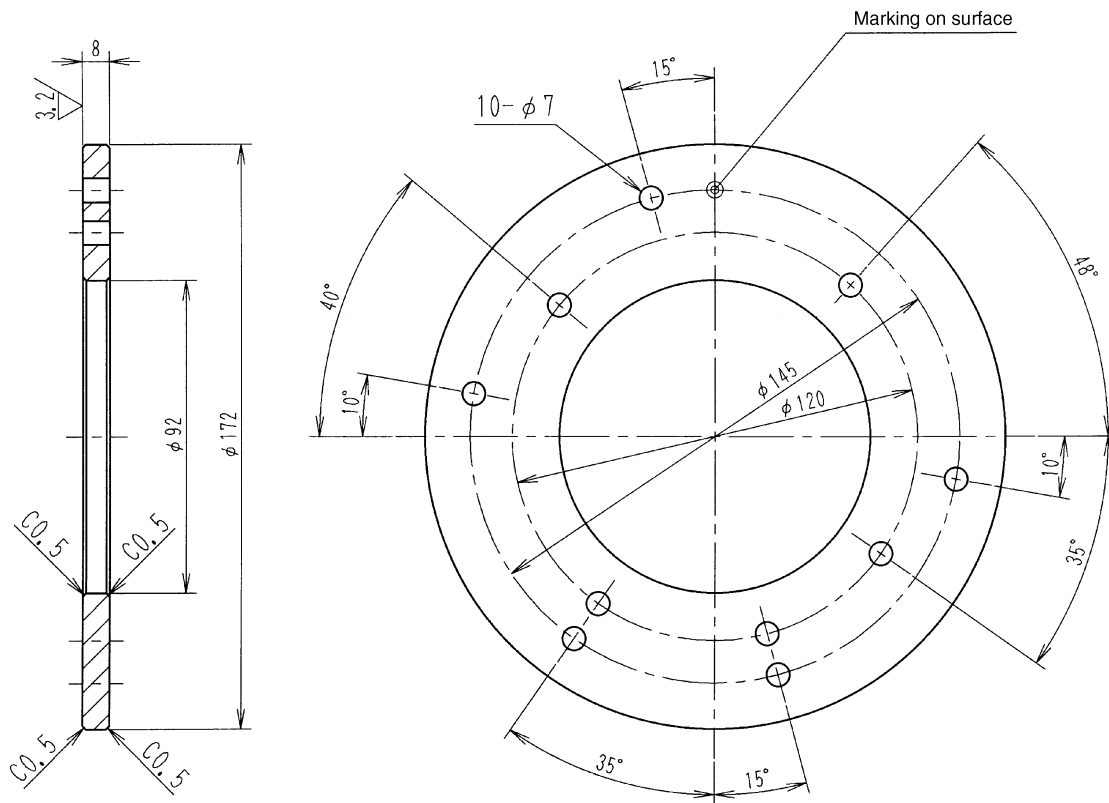

Mount the jig so that the marking appears on the front and top.

(Z0120)

Jig (3) Temporary Bearing Holder Mounting Plate [jig]
[For ZH5_] Material: SS400

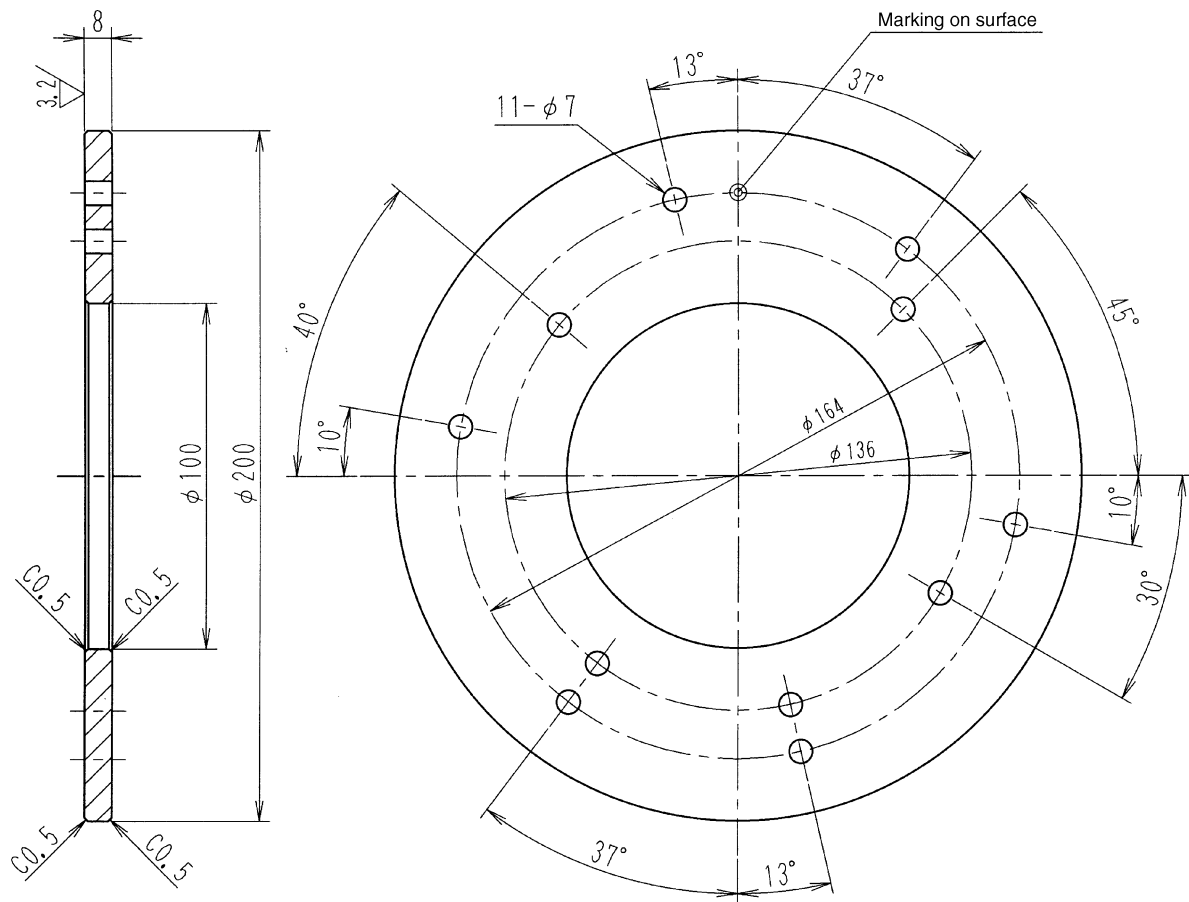

Mount the jig so that the marking appears on the front and top.

(Z0121)

Jig (3) Temporary Bearing Holder Mounting Plate [jig]
[For ZH7_] Material: SS400

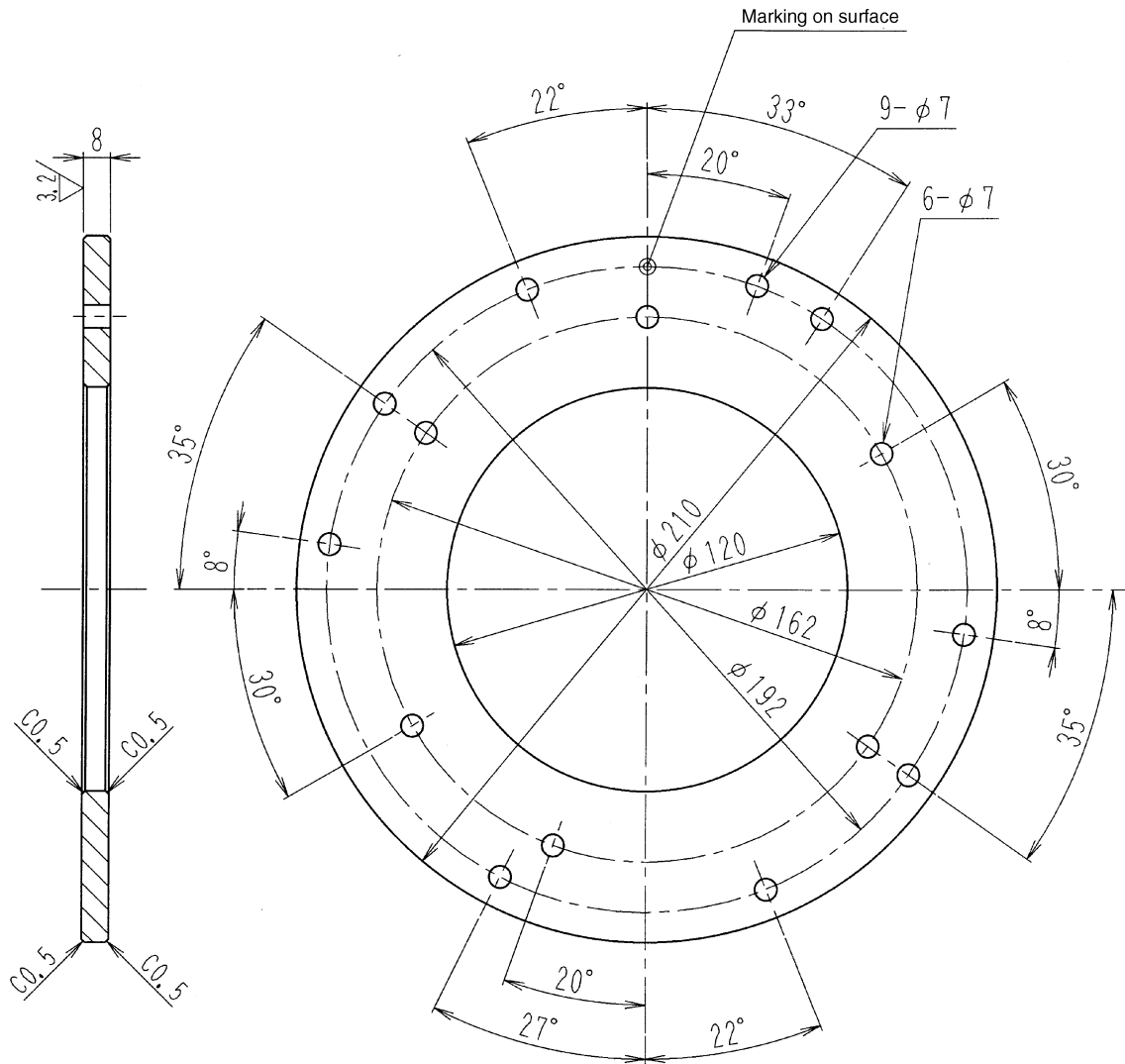

Mount the jig so that the marking appears on the front and top.

(Z0122)

Jig (3) Temporary Bearing Holder Mounting Plate [jig]
[For ZH9_] Material: SS400

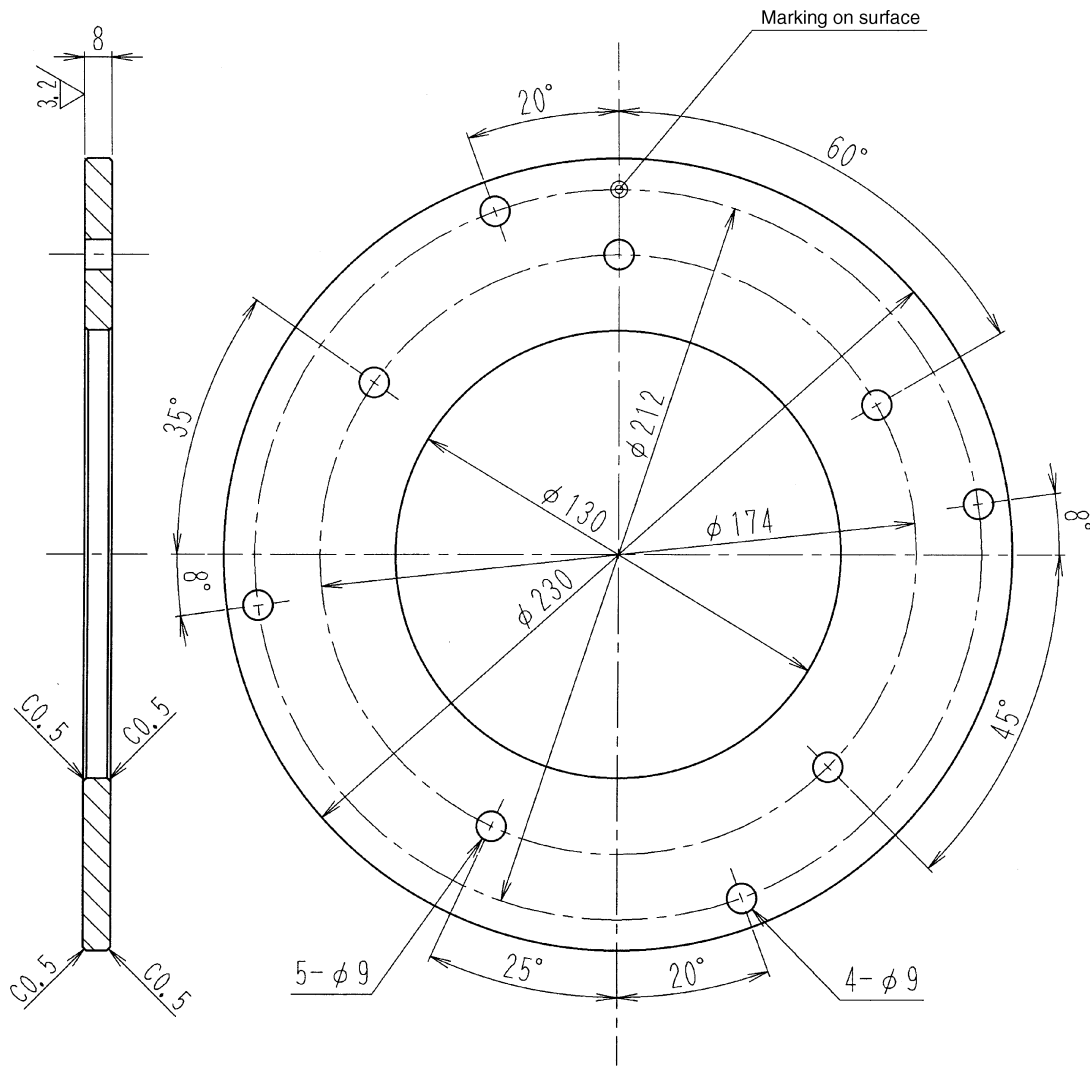

Mount the jig so that the marking appears on the front and top.

(Z0123)

Jig (4)-1 [Handle Jig Set]

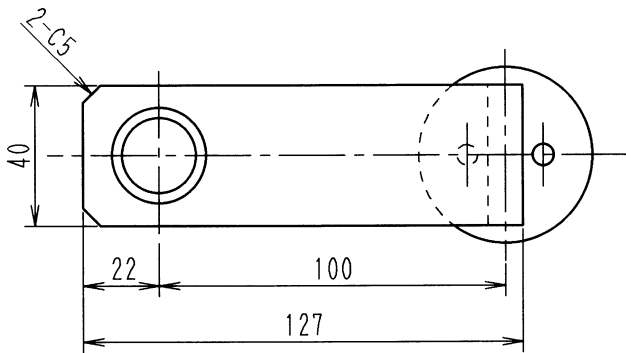

Parts No.	Name	Material	Remarks
①	Handle	STPG370E	20A, sch40 (t2. 9)
②	Stay (1)	SS400 or SM400A	
③	Stay (2)	SS400 or SM400A	
④	Disc	SS400 or SM400A	
⑤	Straight pin	S45C	JIS B1354 Class A or equivalent

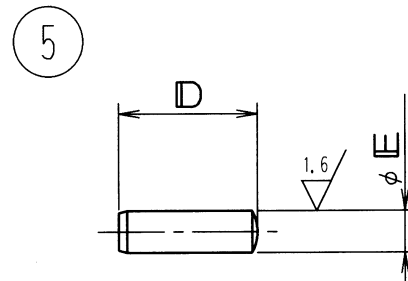
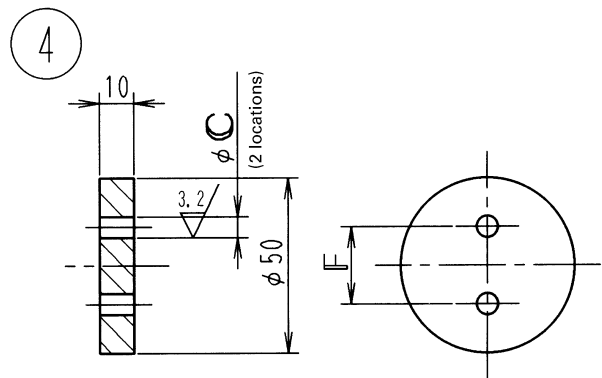
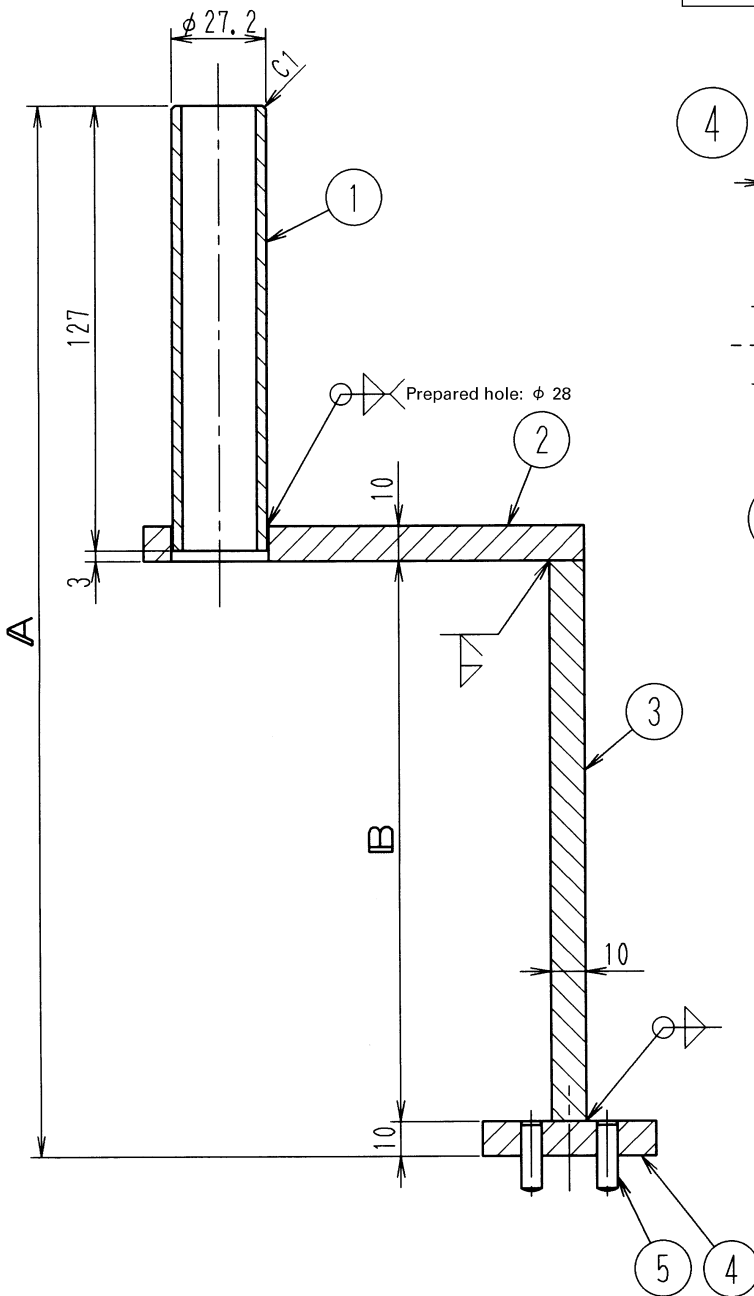

	ZH3_F	ZH5_F
A	300	325
B	160	185
C	6 ^{+0.012} ₀	8 ^{+0.015} ₀
D	20	24
E	6 ^{+0.012} _{+0.004}	8 ^{+0.015} _{+0.006}
F	22	28

(Z0124)

Jig (4)-2 [Handle Jig Set]

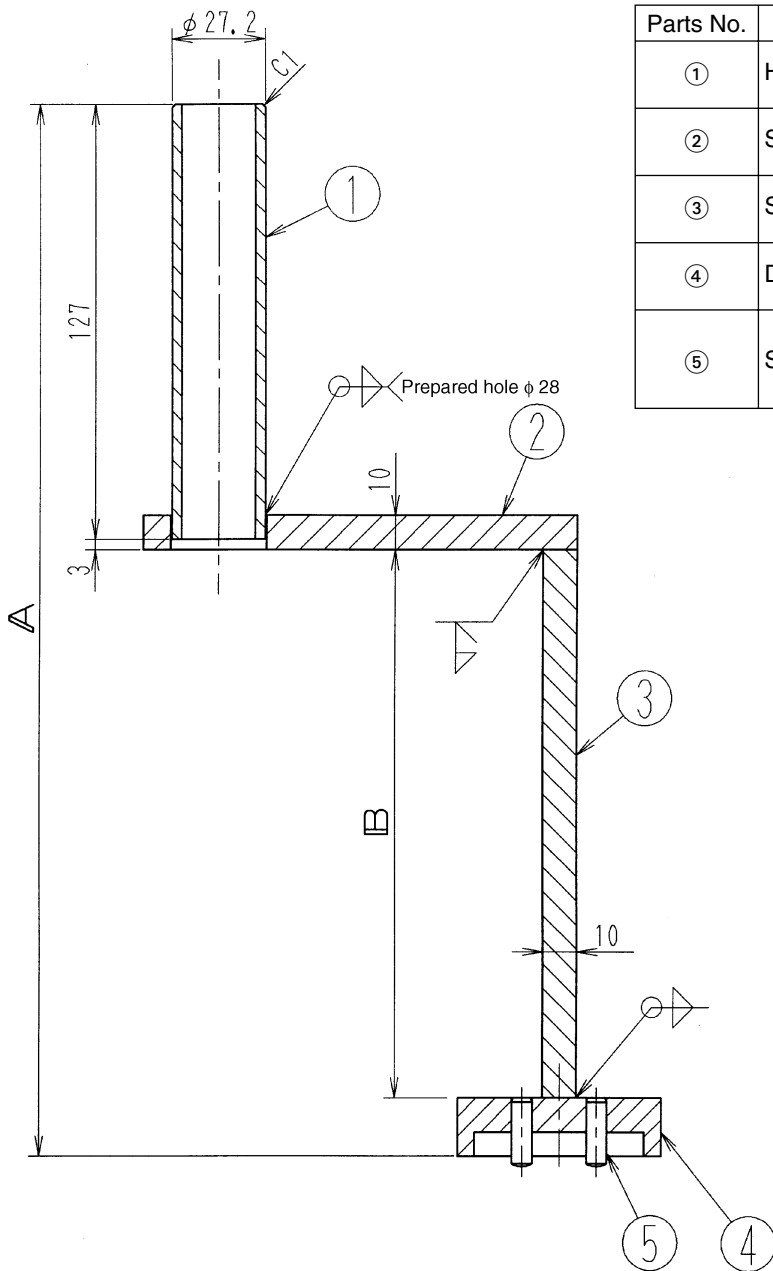
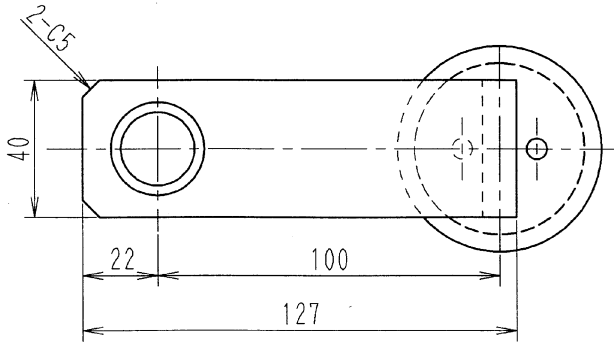

Parts No.	Name	Material	Remarks
①	Handle	STPG370E	20A, sch40 (t2. 9)
②	Stay (1)	SS400 or SM400A	
③	Stay (2)	SS400 or SM400A	
④	Disc	SS400 or SM400A	Refer next page
⑤	Straight pin	S45C	JIS B1354 Class A or equivalent Refer next page

Applicable model	A	B
ZH3_F	307	160
ZH3_G	287	140
ZH5_	333	185
ZH7_	321	170
ZH9_	371	220

(Z0125)

Jig (4)-2 [Handle Jig Parts]

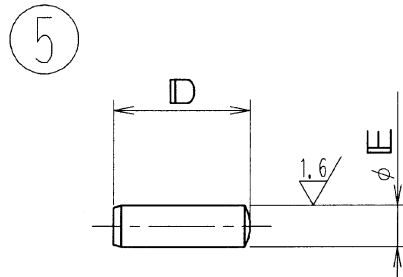
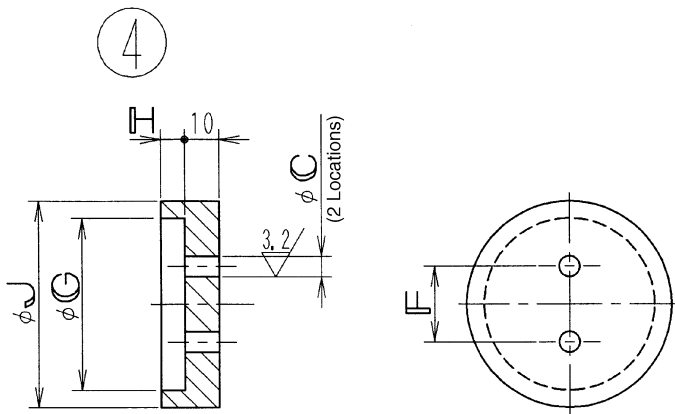

Applicable model	C	D	E	F	G	H	J
ZH3_F	6 ^{+0.012} ₀	20	6 ^{+0.012} _{+0.004}	22	50.5	7	60
ZH3_G	6 ^{+0.012} ₀	20	6 ^{+0.012} _{+0.004}	26	50.5	7	60
ZH5_	8 ^{+0.015} ₀	24	8 ^{+0.015} _{+0.006}	28	60.5	8	70
ZH7_	8 ^{+0.015} ₀	24	8 ^{+0.015} _{+0.006}	32	75.5	11	85
ZH9_	8 ^{+0.015} ₀	24	8 ^{+0.015} _{+0.006}	36	80.5	11	90

(Z0126)

Jig (5) [Oil Filter Removing Jig]
[For ZH3_F]

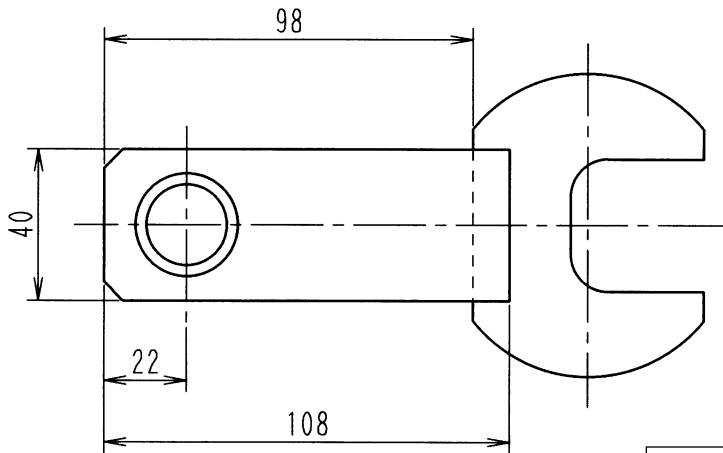

Parts No.	Name	Material	Remarks
①	Handle	STPG370E	20A, sch40 (t2. 9)
②	Stay (1)	SS400 or SM400A	
③	Stay (2)	SS400 or SM400A	
④	Spanner	SS400 or SM400A	

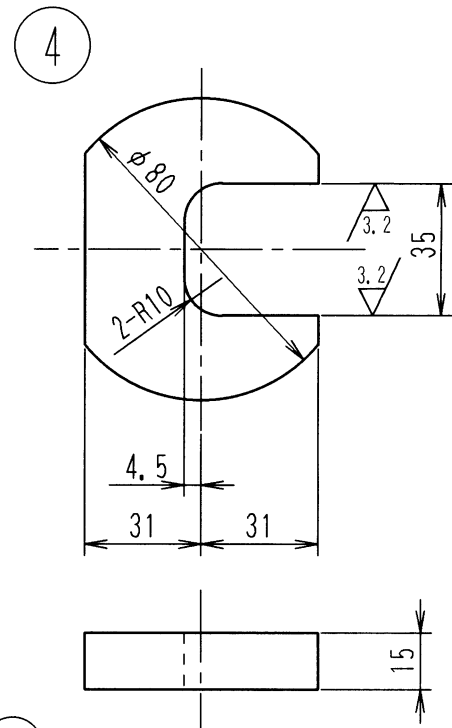
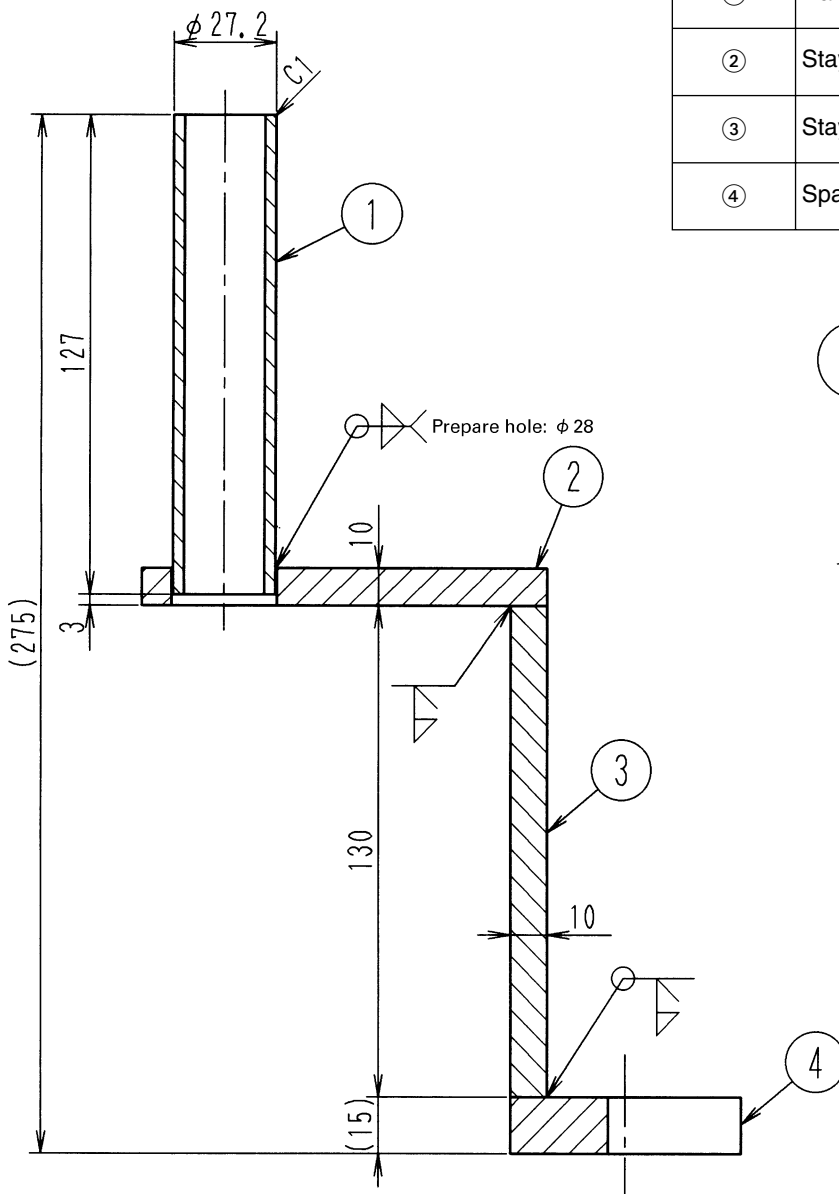

(Z0127)

Index

A		R	
Airtightness Test	29	Remove The Side Caps (One on Each Side) and The Discharge End Cover. (in case of ZH9F, oil collector)	11
Assembling The Screw Shaft and Main Bearing Holder	24	Removing and Disassembling The Screw Assembly Pulley	18
C		Removing and Installation of Gate Rotor	14
Caution in Test Operation	31	Removing Bearings	
Changing Refrigerating Oil		Gate Rotor Bearings (Angular-Contact Bearing, Deep Groove Ball Bearing)	21
Changing Procedure	6	Main Shaft Bearing	20
Charging Oil	30	Removing The Motor Rotor	15
Charging oil	7	Removing The Suction End Cover	14
Cleaning The Suction Filter	9	Replacing The Bearing	20
D		Required Tools	
Disassembling The Gate Rotor and Surrounding Parts	12	List of general tools and measuring instruments	32
Disassembly and Inspection	11	List of special tools	32
Disassembly of The Controller	16	S	
Draining Oil	11	Scope of Application	2
F		T	
Final Assembly	24	Tightening torque values for bolts (N - m)	32
I			
Inserting The Screw Shaft	25		
Inspecting The Gate Rotor	7		
Inspection of The Gate Rotor and Surrounding Parts	12		
Installation of Bearings			
Installing and Adjusting The Gate Rotor Bearings	23		
Main Shaft Bearing	22		
Installing The Discharge End Cover (In case of ZH9F, Oil collector)	28		
Installing The Gate Rotor and Adjusting The Slit Clearance	27		
Installing The Main Bearing Holder Fixing Plate, Assembling The Controller, and Installing The Oil Filter	28		
Installing The Motor Rotor	25		
Installing The Suction End Cover	26		
Insulation Resistance of The Motor	5		
Insulation Resistance Testing			
Measurement Standard	5		
Measuring Procedure	5		
O			
Overhaul	3		
Overhaul Instructions	10		
P			
Periodic Inspection	4		
Periodic Inspection Instructions	5		
Periodic Inspection Items and Intervals	4		
Positioning The Screw Rotor	26		

Drawings & Flow Charts

A		P	
Adjusting clearance between screw rotor and main bearing holder	24	Placing alignment marks on casing and main bearing holder	18
Adjusting piston and installing cylinder cover	28		
Adjusting slit clearance	27	R	
C		Removing C-type retainer ring	20
Cleaning suction filter	9	Removing discharge end cover	11
Cross sectional diagram of controller	16	Removing first demister	11
Cross sectional diagram of gate rotor	12	Removing gate rotor bearing retainer plate	13
D		Removing inner ring of screw shaft bearing	20
Direction of bearings	22, 23	Removing lower bearing holder	13
Disassembling screw assembly	19	Removing lower bearing holder bearing	21
Drain port locations	6	Removing main bearing holder bearing	21
F		Removing main bearing holder fixing plate	17
Front and back sides of angular-contact ball bearing	23	Removing motor rotor	15
I		Removing rotor locking plate	15
Inserting screw shaft	25	Removing screw shaft (1)	18
Inspection of gate rotor chipping	8	Removing screw shaft (2)	19
Inspection of gate rotor surface	8	Removing side cap	11
Installing suction end cover	26	Removing slide valve arm	16
J		Removing suction end cover	14
Jig (1) [Lock Nut Tightening Jig]	33	S	
Jig (2)-1 [Bearing Removing Jig Parts]	35	Screw rotor position	12
Jig (2)-1 [Bearing Removing Jig Set]	34	Service port and oil charge port locations	6
Jig (2)-2 [Bearing Removing Jig Parts]	37	Side cap locations	7
Jig (2)-2 [Bearing Removing Jig Set]	36	Slit clearance measuring location	8
Jig (3) Temporary Bearing Holder Mounting Plate [jig] [For ZH3_] Material: SS400	38	Suction filter location (Cross sectional diagram of casing)	9
Jig (3) Temporary Bearing Holder Mounting Plate [jig] [For ZH5_] Material: SS400	39		
Jig (3) Temporary Bearing Holder Mounting Plate [jig] [For ZH7_] Material: SS400	40		
Jig (3) Temporary Bearing Holder Mounting Plate [jig] [For ZH9_] Material: SS400	41		
Jig (4)-1 [Handle Jig Set]	42		
Jig (4)-2 [Handle Jig Parts]	44		
Jig (4)-2 [Handle Jig Set]	43		
Jig (5) [Oil Filter Removing Jig] [For ZH3_F]	45		
M			
Measurement of gate rotor backlash	12		
Measuring slit clearance on suction side	8		
Motor insulation resistance measuring method	5		
Motor rotor inserting direction	25		
O			
Oil filter removing tool	17		

DAIKIN INDUSTRIES, LTD.

Head office:

Umeda Center Bldg., 4-12, Nakazaki-Nishi 2-chome,
Kita-ku, Osaka, 530-8323 Japan

Tokyo office:

Shinjuku Sumitomo Bldg., 6-1 Nishi-Shinjuku
2-chome, Shinjuku-ku, Tokyo, 163-0235 Japan

DAIKIN EUROPE NV

Zandvoordestraat 300, B-8400 Oostende, Belgium